

WKD 380

Industrial diffuser

catalog 1.1.6





WKD 380

Table of content

Description and benefits	1
Configuration and mode of operation	2
Ranges of application and quick selection	3
Diagrams of performance	
WKD 380 - DN 600	4
WKD 380 - DN 800	5
WKD 380 - DN 1000	6
Acoustic power level and loss of pressure	7
Vertical penetration	7
Dimensions and weight	8
Specifications	9
Codification	9

Presentation and benefits

Swirl chamber diffuser

The WKD 380 diffuser has been specially developed to meet air requirements in areas with high ceilings. Its design allows for installation in free suspension.

The WKD 380 is a high induction swirl diffuser with a round front plate, a turbulence chamber integrated in the plenum, and an adjustable nozzle.

The adjusting mechanisms of the WKD 380 with its adjustable nozzle facilitates the variation of the air jet direction (horizontal to vertical).

The WKD 380 is an excellent choice for an effective and comprehensive system. Regardless of the ventilation mode, heating or cooling, the WKD 380 is efficient in both industrial and commercial setting. The adjustment can be manual or motorized.

Benefits

- Adjustable airflow
- Low acoustic power
- Rapid decrease of speeds and temperature differences
- Reduction of energy costs for air treatment
- Manual or motorized adjustment
- Possibility of changing the air jet penetration force by varying its intensity and induction
- The long-range nozzle allows high vertical penetration in heating mode

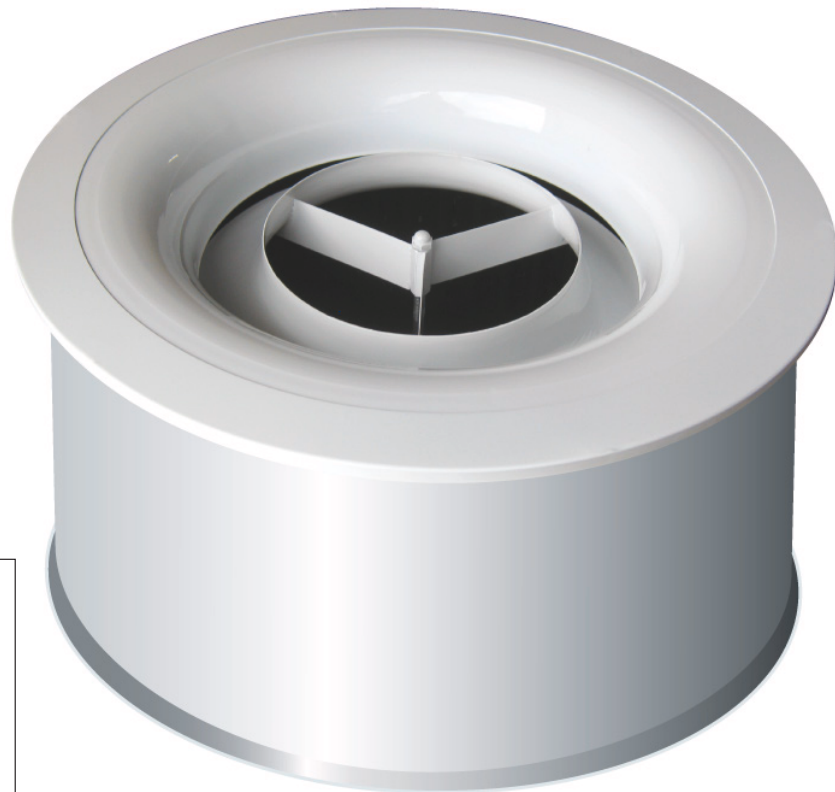

Areas of application

- Commercial spaces
- Theaters
- Exposition Centres
- Stores
- Industrial spaces
- Gymnasiums

Configuration and mode of operation

Configuration

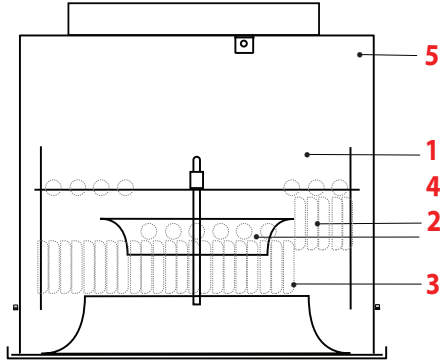

The WKD 380 diffuser is composed of a cylindrical swirl chamber (1), around which are placed blades to direct air (2) to the deflector (3), and an long-range nozzle adjustable manually or motorized (4). These components are located in a plenum (5). This diffuser is available in nominal sizes 600/800/1000. It is adapted for heights up to 30 m and speeds of up to 9000 m³/h per diffuser. The diffuser is powder coated with a polyester TGIC-free paint, providing a smooth, easy-to-clean, chip and fade resistant finish. The colours are available from the RAL colour chart.

Mode of operation

The air flow entering the turbulence chamber (1) creates an intensive helical movement, depending on the positioning of the nozzle (4). The airflow at the deflector outlet (3) will produce air induction and a variable penetration.

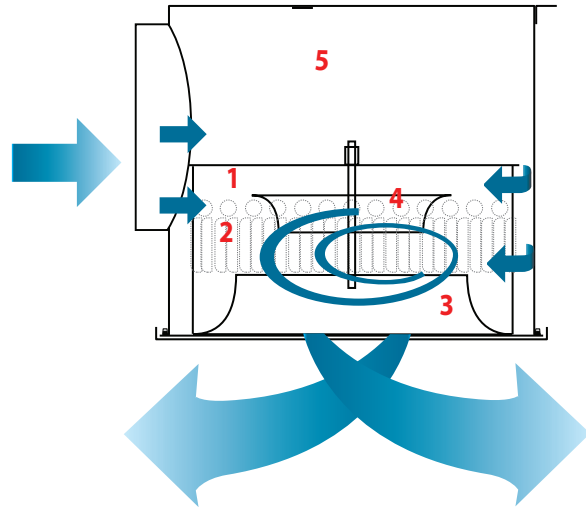

Operation

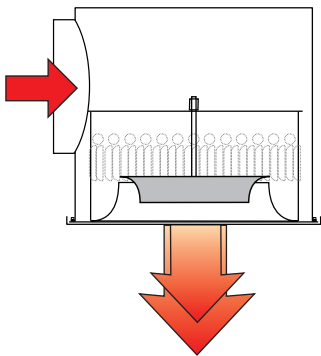

Heating

Nozzle Position 1
Stable vertical air flow
with large penetration

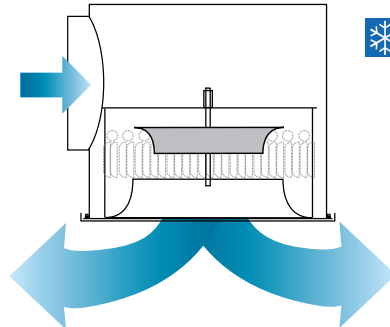

Cooling

Nozzle Position 3
Horizontal helical air flow
and a relatively weak reach

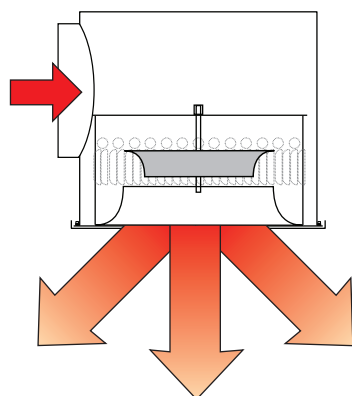

Nozzle Position 2
Vertical airflow with
a helical effect

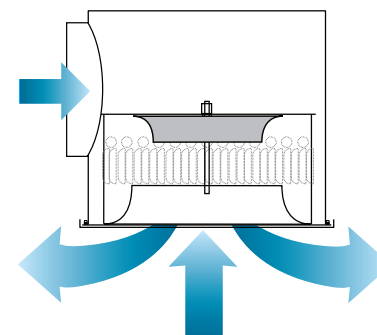

Nozzle Position 4
Horizontal air flow
(even in free suspension)
with a maximal
horizontal reach and an
elevated primary induction

Ranges of application and quick selection

	L_{WA} (dB(A))	\dot{V}_0 (m ³ /h)	Δp (Pa)	Minimum space (m)	y (m)
DN 600	30	650	14	~2	4.0
	40	900	27	~2	6.0
	50	1200	50	3	8.0
DN 800	40	1550	12	~2	6.5
	50	2400	28	3	10.0
	60	3600	65	8	12.0
DN 1000	45	2400	14	2	6.0
	55	3600	33	7	9.0
	65	5500	75	14	12.0

Specification : The minimum space for an installation height of 4 m for the airflow speed in the occupied zone which won't exceed 0.2 m/s
The penetration length in heating mode is $\Delta T = +10^\circ\text{C}$.

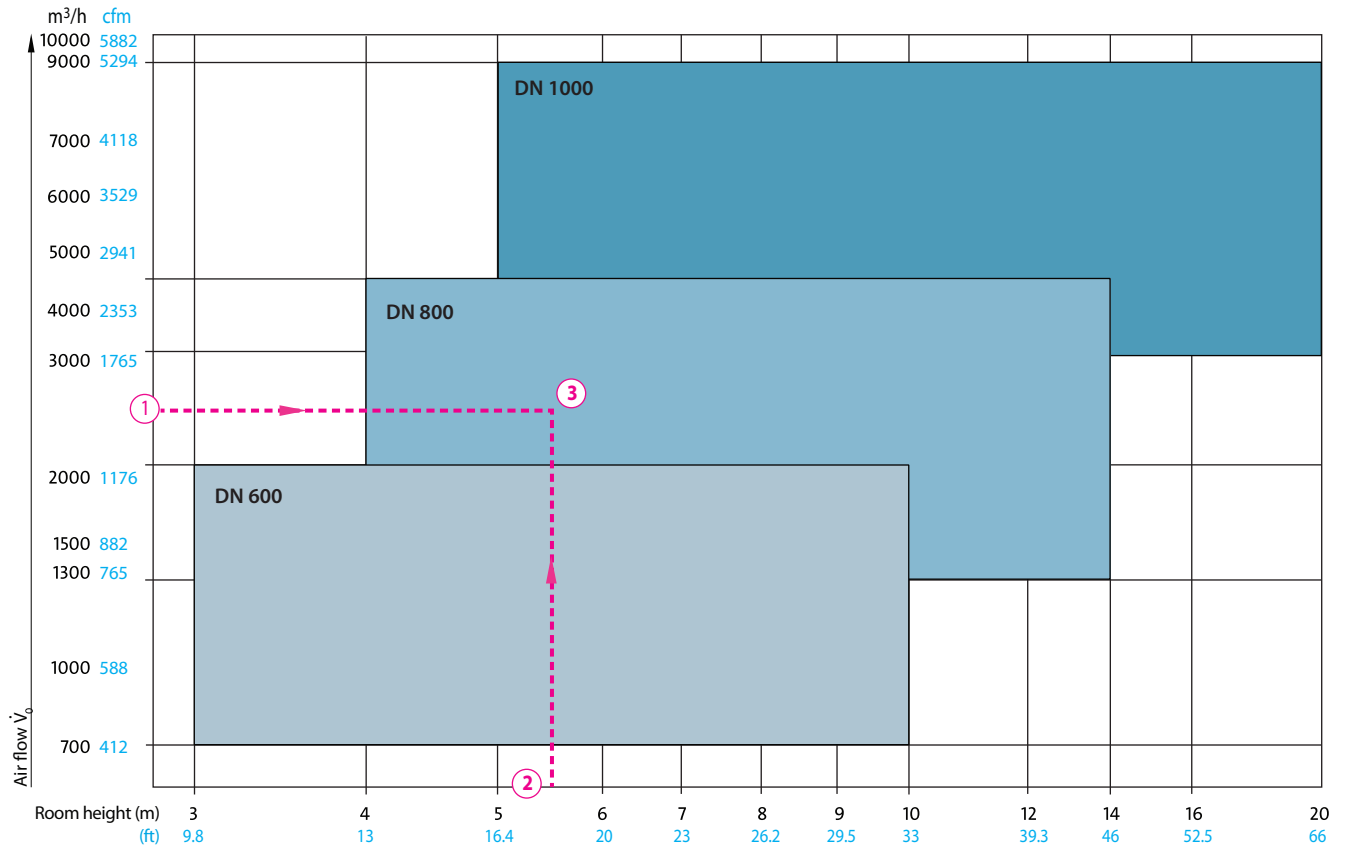

Performance diagrams

DN 600 in free suspension without ceiling influence

Note:
With the influence of
the ceiling, the
velocities must be
multiplied by a
factor of 1.4.

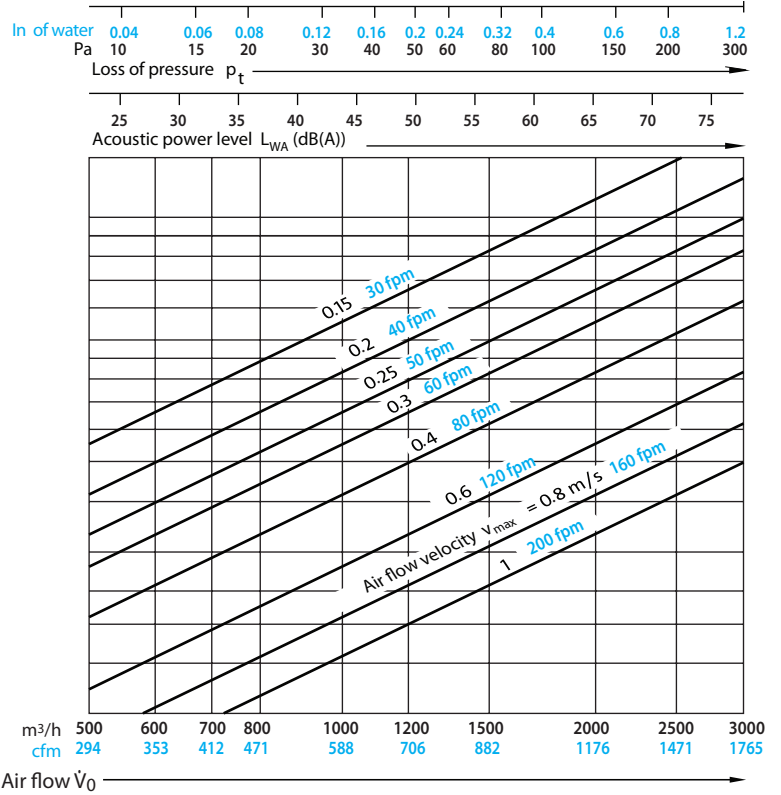
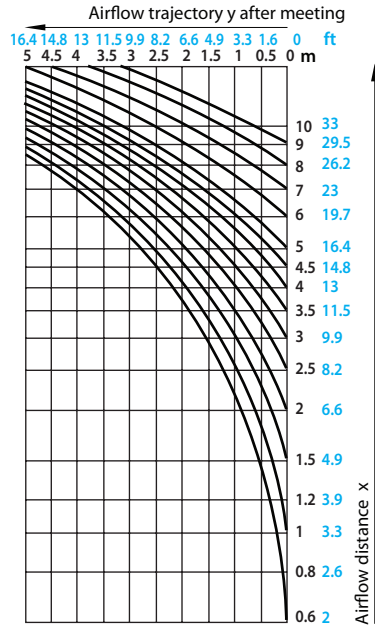

Air flow deflection



in heating

Airflow in free suspension
without the influence from
the ceiling by temperature
difference ratio

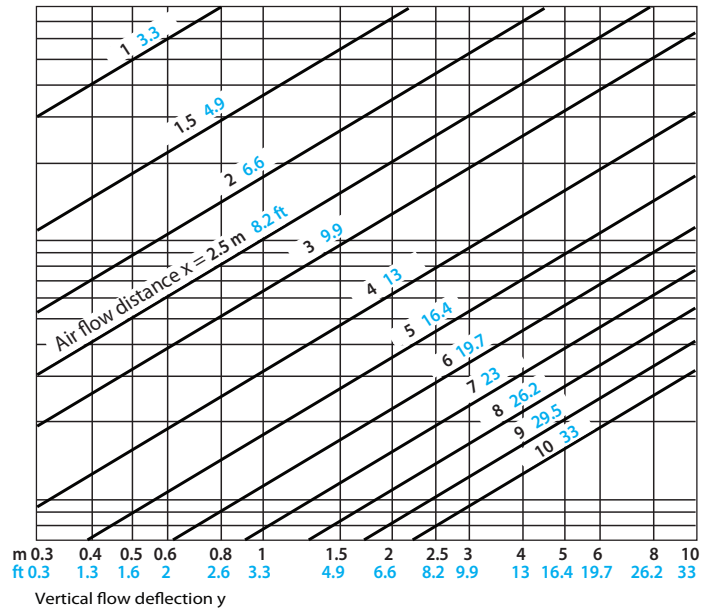
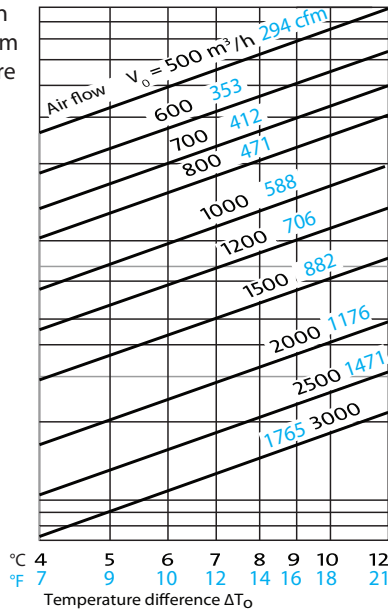

Performance diagrams

DN 800 in free suspension without ceiling influence

Note:
With the influence of
the ceiling, the
velocities must be
multiplied by a
factor of 1.4.

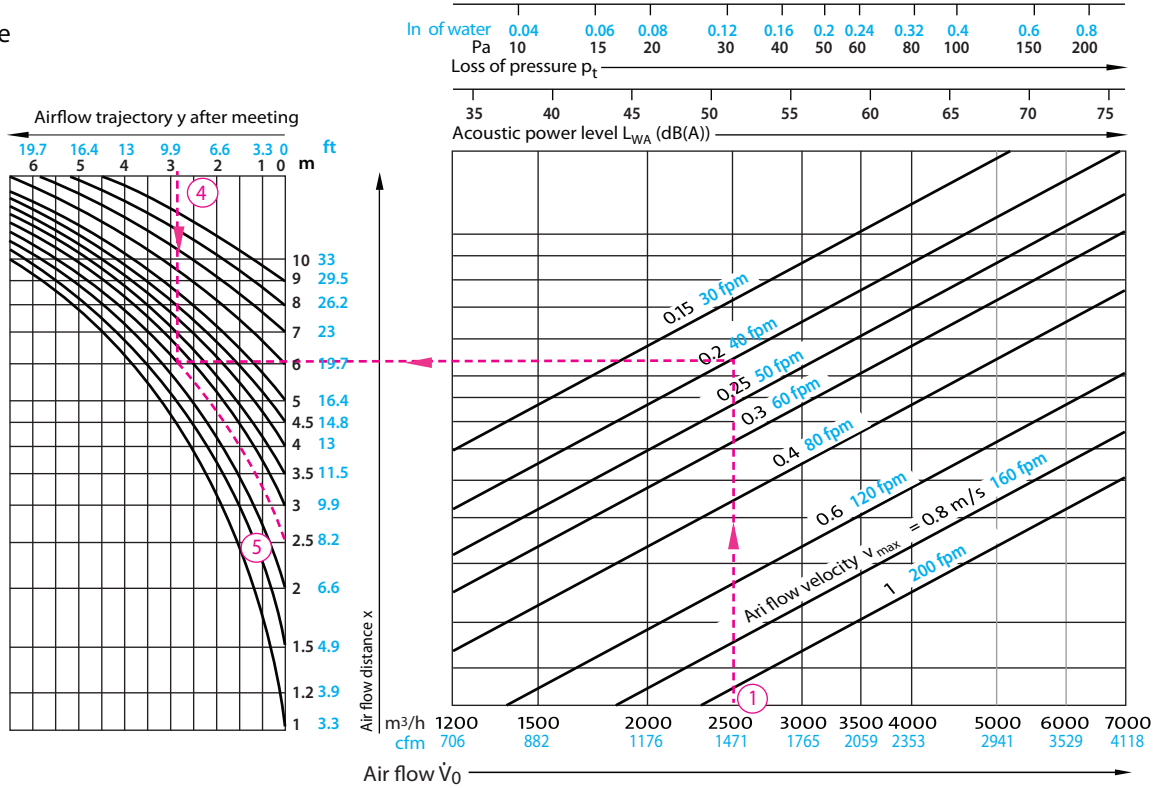

Air flow deflection in heating

Airflow in free suspension
without the influence from
the ceiling by temperature
difference ratio

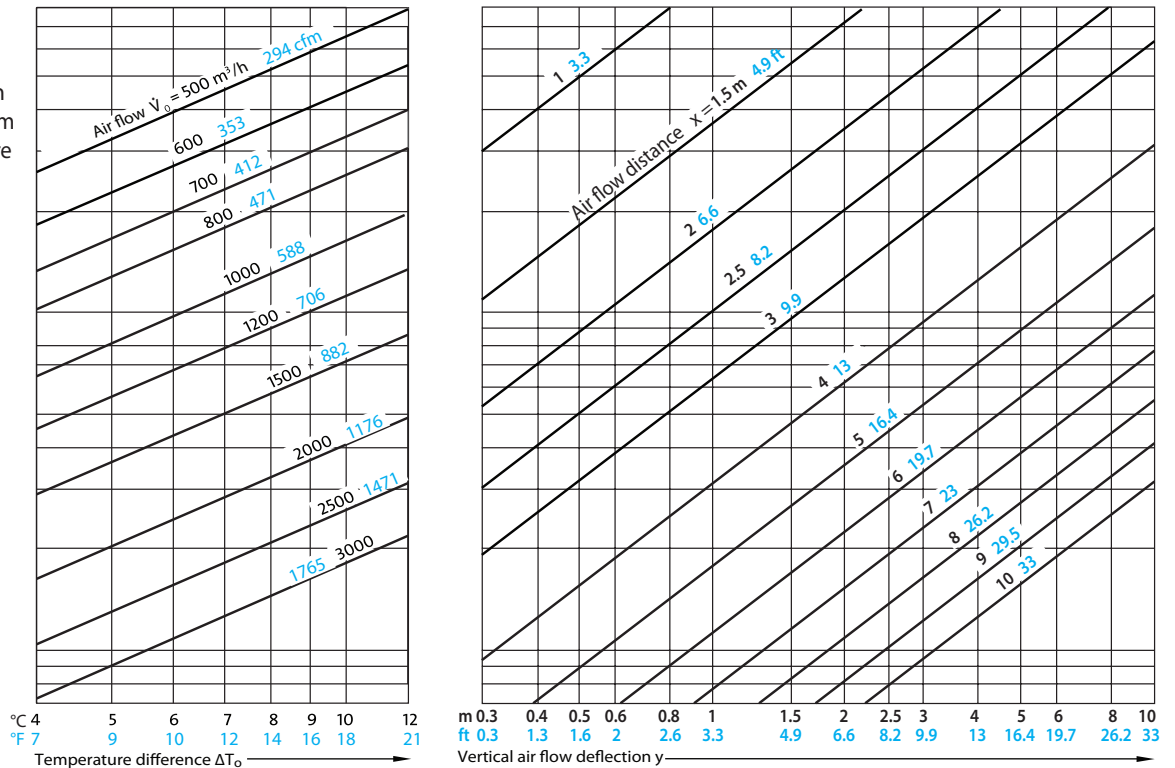

Performance diagrams

DN 1000 in free suspension without ceiling influence

Note:
With the influence of
the ceiling, the
velocities must be
multiplied by a
factor of 1.4.

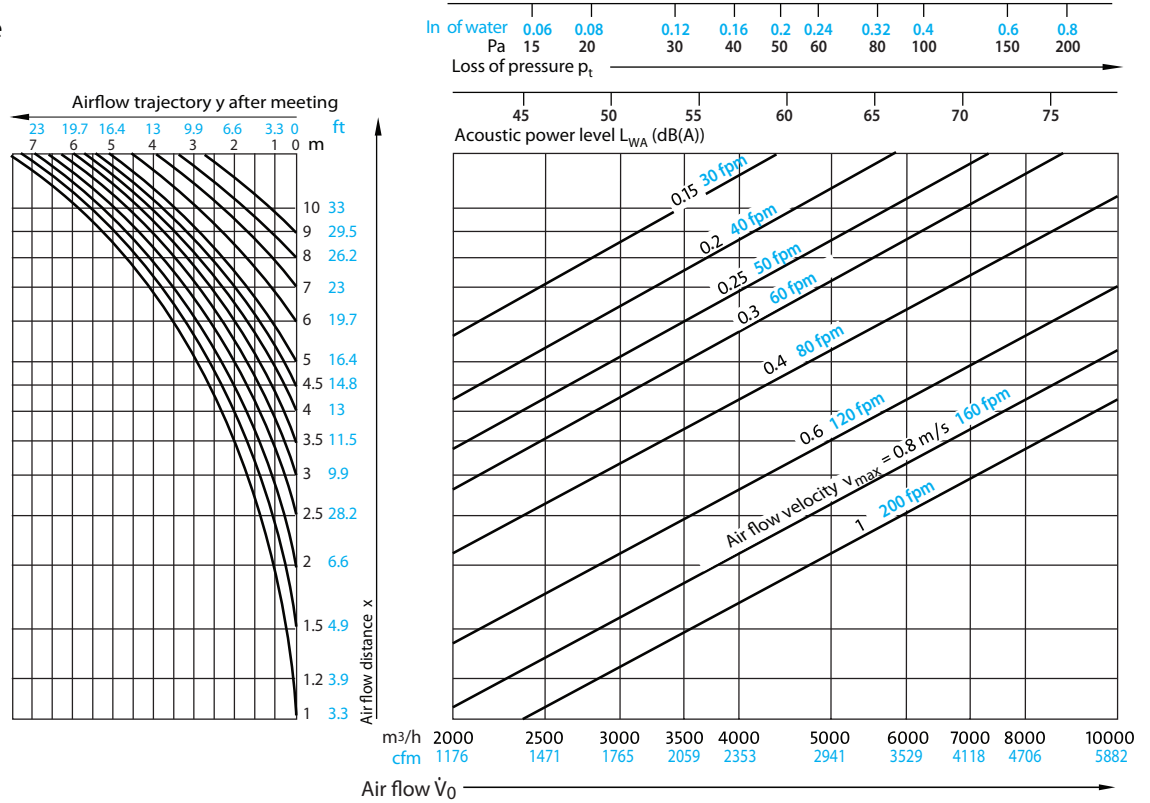

Air flow deflection in heating

Airflow in free suspension
without the influence from
the ceiling by temperature
difference ratio

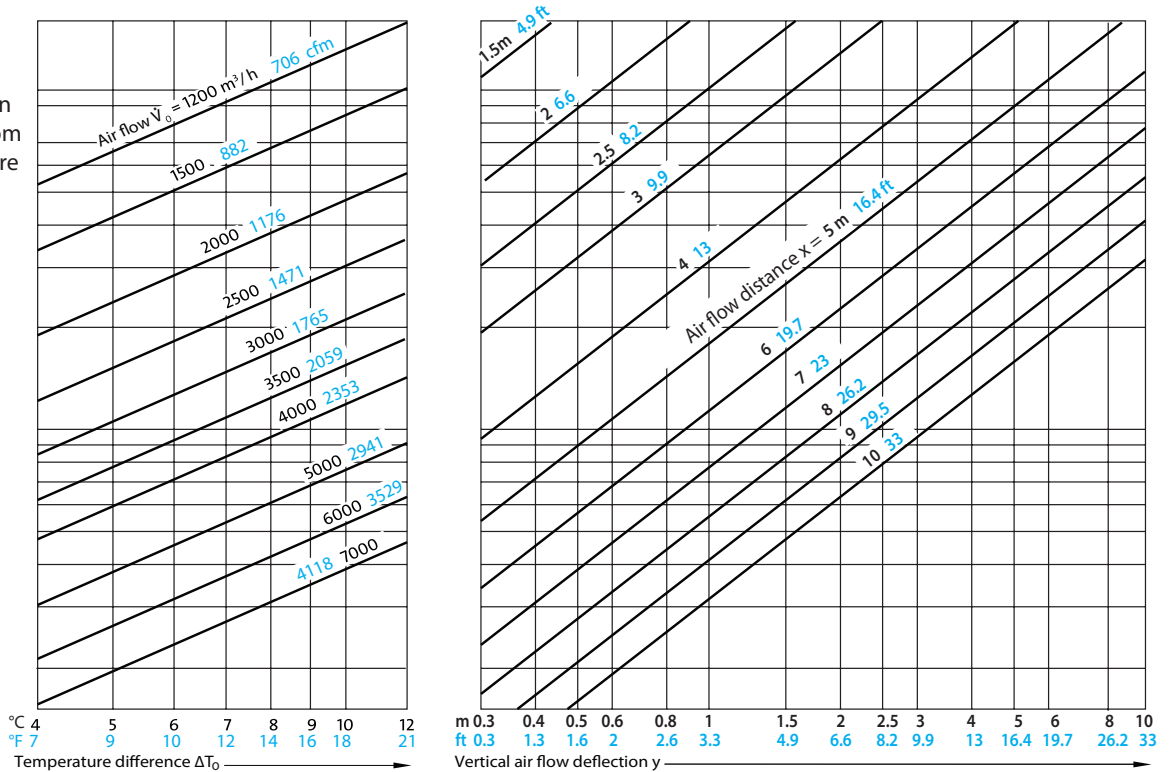

Acoustic power level and loss of pressure

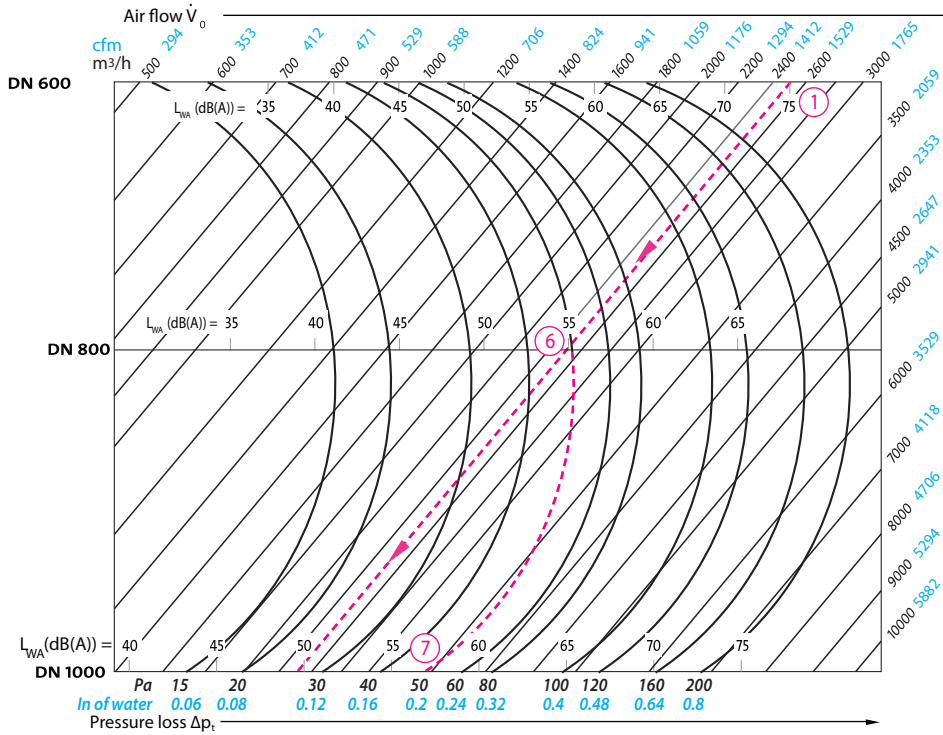

Specifications:

- Height of the room 5.5 m (18 ft) **2**
- Height of the installation: 4.0 m (13 ft)
- Maximum air flow speed at a height of 1.8m: 0.2 m / s
- Air flow: 2500 m^3/h **1**

Required:

- 1- Dimension of the diffuser
- 2- Minimum space between the diffusers
- 3- Acoustic power L_{WA}
- 4- Loss of pressure Δp_t

Solution:

- From the "Ranges of Application" diagram, we obtain DN 800 as the size
- From "Performance charts" and for an air volume flow of 2500 m^3/h :
 $y = \text{Installation height} = 4 \text{ m} - 1.8 \text{ m} = 2.2 \text{ m}$ **4**
 we find the airflow distance:
 $x = 2.5 \text{ m}$ **5**
 thus, minimum clearance between diffusers = $2 \times 2.5 \text{ m} = 5 \text{ m}$

- 3 and 4. From the diagram "Acoustic power level and loss of pressure" we find: $L_{WA} = 55 \text{ dB}$ **6**
 $\Delta P_t = 50 \text{ Pa}$ **7**

Important

Acoustic absorption of the room is not accounted for. For a comparison with north american values, reduce the acoustic power by ten (10) dB. The values are based on an isothermal flow.

Vertical penetration



in heating

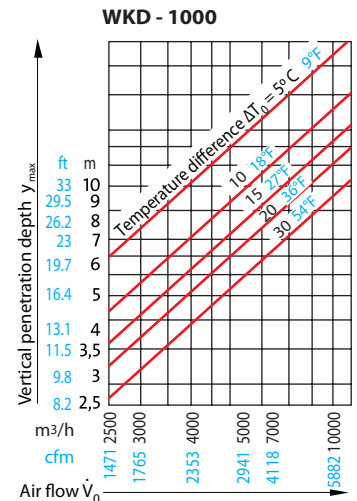
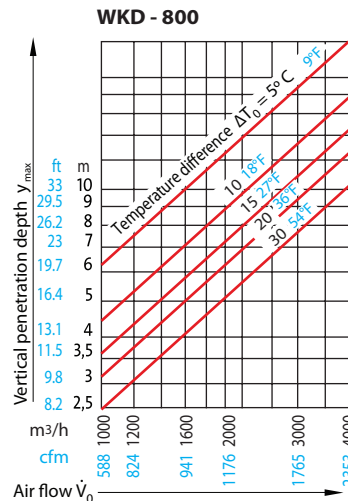
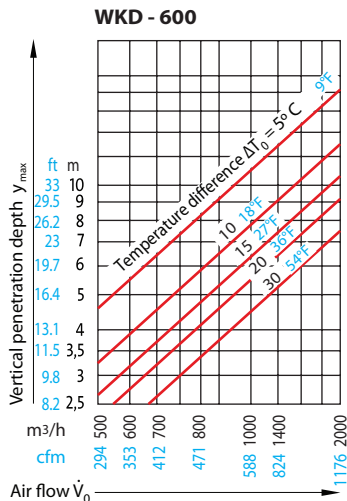

Dimensions and weight

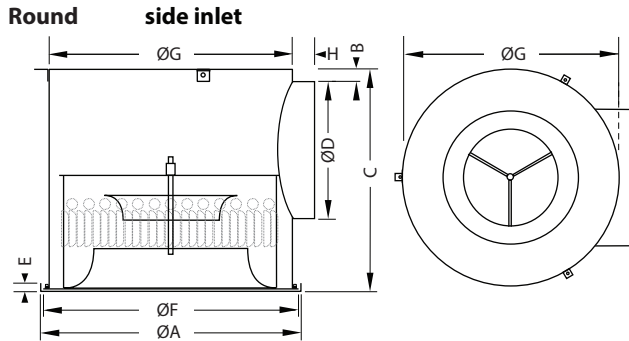

	DN 600 (mm)	DN 800 (mm)	DN 1000 (mm)
Size ØA	600	800	1080
Size B	33	50	50
Size C	504	701	803
Size ØD	403	505	607
Size E	7	7	7
Size ØF	586	787	1066
Size ØG	560	760	1040
Size H	50	50	50
Weight (kg)	27,5	53	66,3

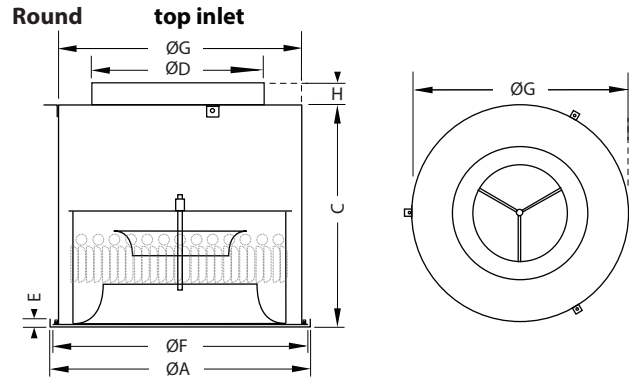

	DN 600 (mm)	DN 800 (mm)	DN 1000 (mm)
Size ØA	600	800	1080
Size C	504	701	803
Size ØD	403	505	607
Size E	7	7	7
Size ØF	586	787	1066
Size ØG	560	760	1040
Size H	50	50	50
Weight (kg)	27,5	53	66,3

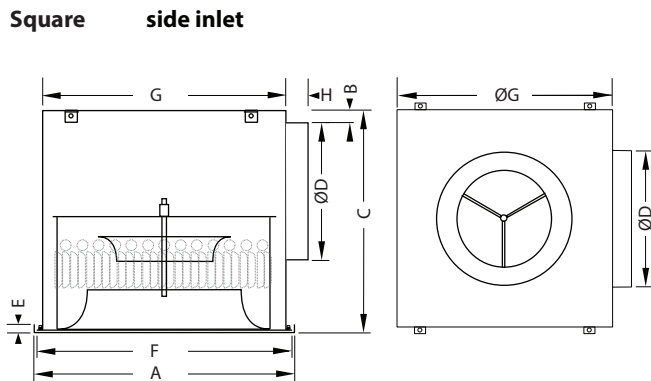

	DN 600 (mm)
Size A	603
Size B	33
Size C	504
Size ØD	403
Size E	12
Size F	565
Size G	552
Size H	50
Weight (kg)	27,5

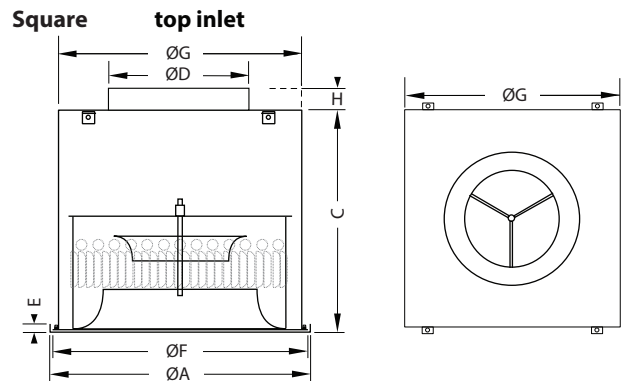

	DN 600 (mm)
Size A	603
Size C	504
Size ØD	403
Size E	12
Size F	565
Size G	552
Size H	50
Weight (kg)	27,5



WKD 380

Specifications

1- Description and physical characteristics

- 1.1 The air swirl diffuser shall be made of steel. The square or round diffuser shall be equipped with an adjustable nozzle to guide the air flow.
- 1.2 The diffuser shall be equipped with a turbulence chamber composed of a round plate with stamped blades.
- 1.3 The diffuser adjustment mechanism shall be available in manual and motorized modes.
- 1.4 The diffuser shall be powder coated with a polyester TGIC-free paint, providing a smooth, easy-to-clean, chip and fade resistant finish. The architect or client shall choose a standard colour from the RAL colour chart.
- 1.5 The plenum is produced with a galvanized steel, non painted finish.
A power coated finish option is available.

2 - Performance

The performance shall be guaranteed by using performance curves or simulation software for critical areas. These curves shall indicate the pressure drop, acoustic power generated as well as showing a cross-sectional view illustrating the critical airflow path in cooling, isothermal and heating modes. This critical airflow path shall have a rated speed at 1.8 m (6 ft) from the ground in occupied area or as requested by the engineer.

3 - Installation

The swirl diffuser shall be mounted on a galvanized steel plenum supplied by the manufacturer.

4 - Balancing

The diffuser balancing shall be executed by a ventilation system balancing technician holding a certificate of qualification.

5 - Quality Requirements: NAD Klima, model WKD 380

Codification

WKD 380	Product
Q = Square (only DN 600) R = Round	Configuration
0600, 0800, 1000	Nominal dimension
9003 = White 9010 = Cream 00SB = Solar Black (Standard matte black) 00SM = Silver Matte (Standard metallic grey) ____ = RAL color (write the RAL color number)	Diffuser color
T = Plenum with inlet on the top S = Plenum with inlet on the side	Plenum
H = Hand adjustment M = Motorized adjustment	Adjustment
WKD380 - Q - 0600 - 9003 - T - H - X	Example



www.nadklima.com

NAD Klima (Head office)

144, rue Léger,
Sherbrooke, QC, J1L 1L9 Canada
T: 819 780-0111 • 1 866 531-1739
F: 819 780-1660s
info@nadklima.com

NAD Klima Ontario

2840, Argentia Road, Unit 6,
Mississauga, ON, L5N 8G4 Canada
T: 416-860-1067
ontario@nadklima.com

