

# QAL

Air displacement diffuser  
catalog 1.1.5











**QAL**

---

**QAL-R in workshop at Nad Klima, Canada**

Areas of application, dimensions and aerodynamic data

QAL - L

Wall installation

Areas of application

The three ranges of airflow for the shape, the dimension and the height data are based on the speed of air exiting the diffuser. These speeds represent the diffuser's total surface (at the frontal plate).

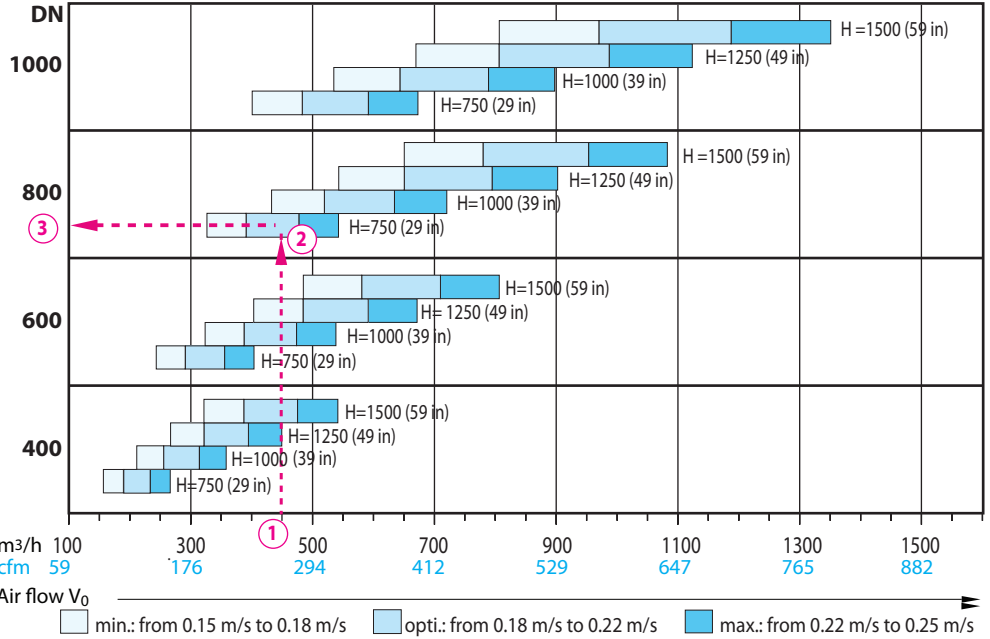
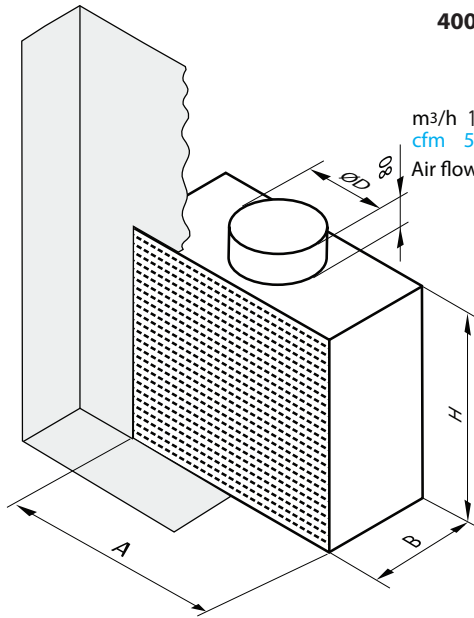

Aerodynamic data

	Height (mm)	$\dot{V}_{min}$ (m³/h)	$\dot{V}_{max}$ (m³/h)	$\dot{V}_{nom.}$ (m³/h)	$\dot{V}_{nom.}$ Δp(Pa)	$\dot{V}_{nom.}$ L <sub>WA</sub> (dB(A))	$\dot{V}_{nom.}$ L (m)
DN 400	750	160	270	220	4	< 20	1.3
	1000	220	360	290	5	< 20	1.6
	1250	270	450	360	5	< 20	1.8
	1500	320	540	430	5	20	2.0
DN 600	750	240	400	320	4	< 20	1.5
	1000	320	540	430	5	21	1.9
	1250	400	670	540	7	22	2.3
	1500	490	810	650	9	24	2.8
DN 800	750	320	540	430	5	22	1.8
	1000	430	720	580	9	26	2.6
	1250	540	900	720	10	27	3.1
	1500	650	1080	860	12	28	3.7
DN 1000	750	400	680	540	6	25	2.2
	1000	540	900	720	10	27	3.0
	1250	670	1120	900	14	29	3.6
	1500	810	1350	1080	15	30	4,2

$V_{min}$ : Airflow for a velocity loss of 0.15 m/s  
 $V_{max}$ : Airflow for a velocity loss of 0.25 m/s  
 $V_{nom.}$ : Airflow for a velocity loss of 0.2 m/s  
 L: Diffuser horizontal distance for  $\Delta T_0 = -2^\circ C$ .  
 Then the airflow speed is:  $\leq 0.25$  m/s

Dimensions

	DN 400				DN 600				DN 800				DN 1000			
Size A	406				610				813				1016			
Size B	330				381				381				406			
Size ØD	150	150	200	200	200	200	250	250	200	2250	250	300	250	250	300	300
Size H	750	1000	1250	1500	750	1000	1250	1500	750	1000	1250	1500	750	1000	1250	1500

**Sizing diagrams**  
QAL - L

**Example**

**Data**

Height: 750 mm (29.5 po) **2**  
 Flow: 265 cfm 450 m<sup>3</sup>/h **1**  
 Temperature difference: -6°C **5**  
 Max. airflow velocity at ground level: 0,2 m/s **4**

**Required**

DN:  $x: \Delta T_x / \Delta T_0: \Delta p_t: L_{WA}$

**Solution**

From the "Areas of application" diagram follow we find DN 800. **3**

From the "Sizing diagram", when applying the correction table, we find:

$x = 3.4$  m (for  $V_x \times 0.94$ ) **6**

$\Delta T_x / \Delta T_0 = 0.25 \times 0.86 = 0.22$  **7**

$\Delta p_t = 5 \times 1.25 = 6.25$  Pa **9**

$L_{WA} = 21 + 3 = 24$  dB (A) **8**

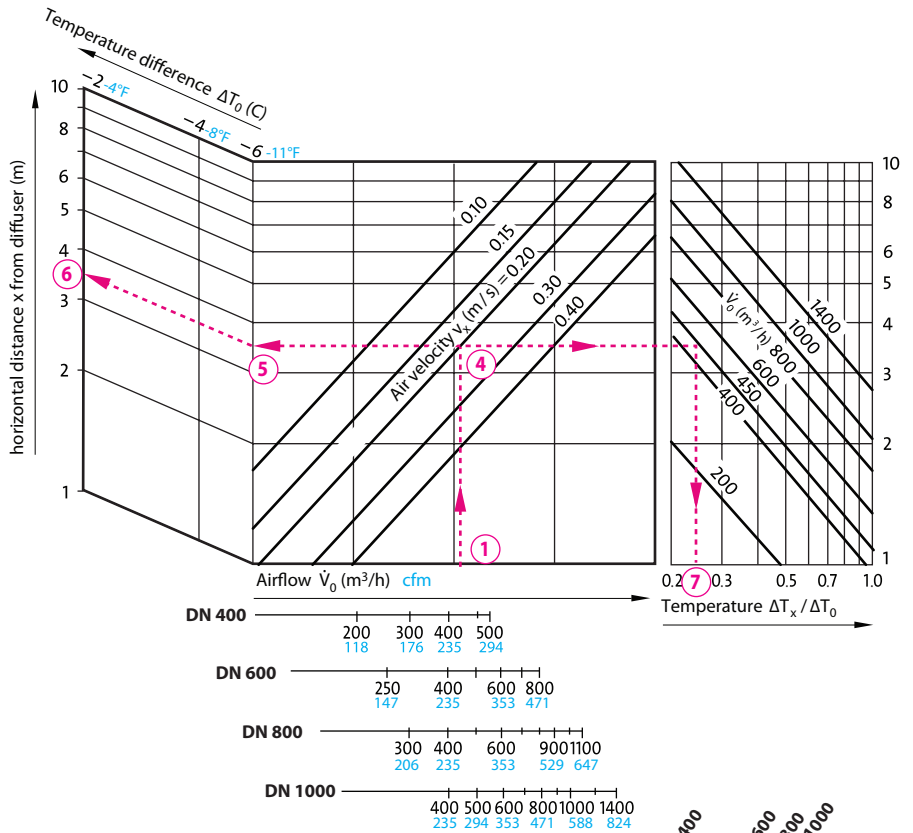

**Correction table**

	Height (mm)			
	750	1000	1250	1500
$v_x$	x 0.94	x 1.00	x 1.04	x 1.07
$\Delta T_x / \Delta T_0$	x 0.86	x 1.00	x 1.11	x 1.22
$\Delta p_t$	x 1.25	x 1.00	x 0.80	x 0.65
$L_{WA}$ (dB(A))	+3	± 0	-3	-6

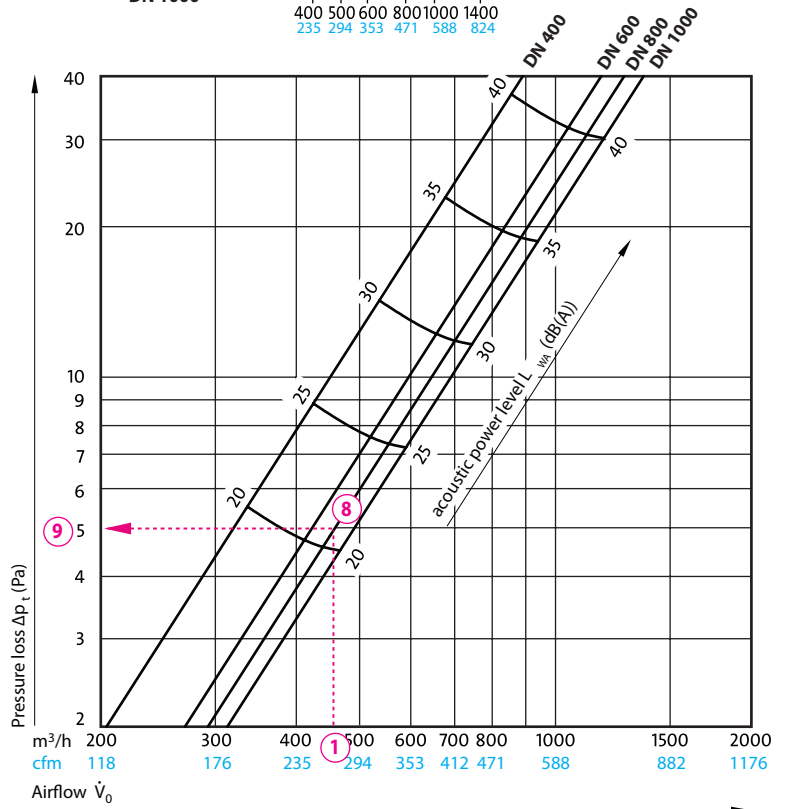

**Areas of application, dimensions and aerodynamic data**  
**QAL - R**

**Round displacement diffuser (360°), floor installation**

**Areas of application**

The three ranges of airflow for the shape, the dimension and the height data are based on the speed of air exiting the diffuser. These speeds represent the diffuser's total surface (at the frontal plate).

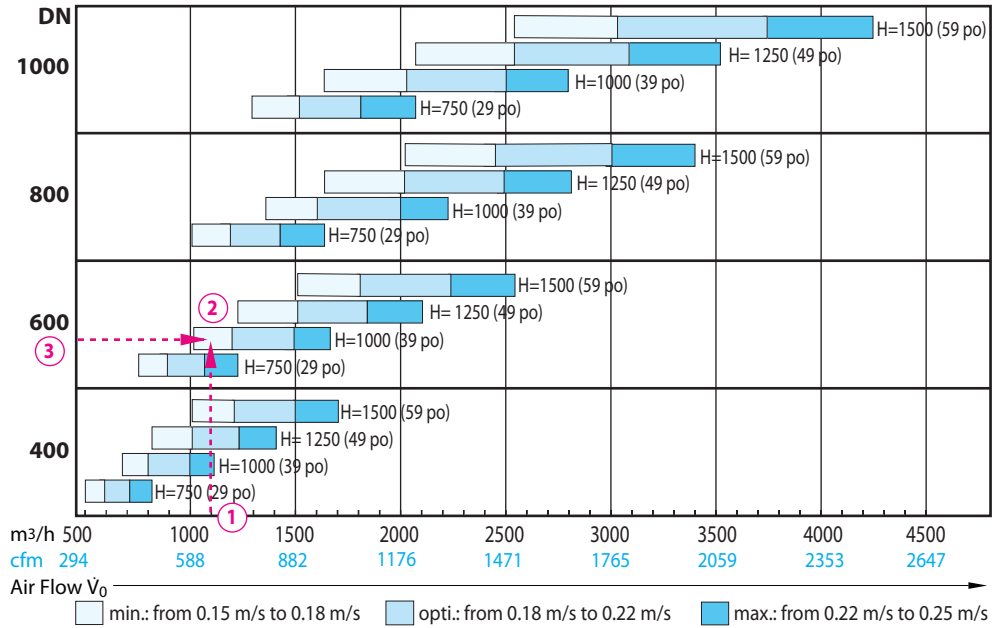
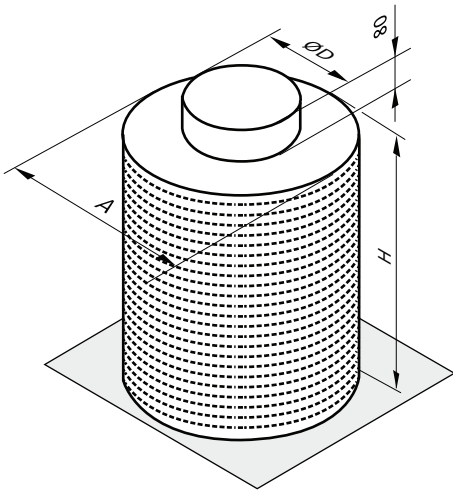

**Aerodynamic data**

Nominal size	Height (mm)	$\dot{V}_{min}$ (m³/h)	$\dot{V}_{max}$ (m³/h)	$\dot{V}_{nom.}$ (m³/h)	$\dot{V}_{nom.}$ $\Delta p$ (Pa)	$\dot{V}_{nom.}$ $L_{WA}$ (dB(A))	$\dot{V}_{nom.}$ L (m)
DN 400	750	500	850	680	15	28	1,3
	1000	680	1130	900	20	31	1,6
	1250	850	1410	1130	25	32	1,9
	1500	1020	1700	1360	32	34	2,3
DN 600	750	760	1270	1020	19	33	1,5
	1000	1020	1700	1360	30	36	2,3
	1250	1270	2120	1700	40	38	2,5
	1500	1530	2540	2040	41	39	2,8
DN 800	750	1020	1700	1360	25	36	2,0
	1000	1360	2260	1810	35	40	2,6
	1250	1700	2830	2260	40	41	3,0
	1500	2040	3390	2710	50	42	3,5
DN 1000	750	1270	2120	1700	31	38	2,5
	1000	1700	2830	2260	36	41	3,0
	1250	2120	3530	2830	48	43	3,7
	1500	2540	4240	3390	57	45	4,5

$V_{min}$ : Airflow for a velocity of 0.15 m/s  
 $V_{max}$ : Airflow for a velocity of 0.25 m/s  
 $V_{nom}$ : Airflow for a velocity of 0.2 m/s  
 L: Horizontal distance of the diffuser for  $\Delta T_0 = -2^\circ C$ .  
 Then the airflow is:  $\leq 0.25$  m/s

**Dimensions**

	DN 400				DN 600				DN 800				DN 1000			
Size A	406				610				813				1016			
Size ØD	229	280	305	356	254	356	381	406	356	406	457	508	381	457	508	559
Size H	750	1000	1250	1500	750	1000	1250	1500	750	1000	1250	1500	750	1000	1250	1500



**Sizing diagrams**  
**QAL - R**

**Example**

**Data**

DN: 600 (2)  
 Flow: 647 cfm 1100 m<sup>3</sup>/h (1)  
 Temperature difference: -4°C (5)  
 max. airflow speed at ground level: 0.2 m/s (4)

**Required**

Height: x:  $\Delta T_x / \Delta T_0$ :  $\Delta p_t$ : LWA

**Solution**

From the "Ranges of application" diagram we find a height of 1000 mm (39 po). (3)  
 From the "Sizing diagram", when applying the correction table, we find:  
 $x = 2.3$  m (for  $v_x \times 1$ ) (6)  
 $\Delta T_x / \Delta T_0 = 0.56 \times 1 = 0.56$  (7)  
 $\Delta p_t = 17 \times 1 = 17$  Pa (9)  
 $LWA = 31 + 0 = 31$  dB (8)

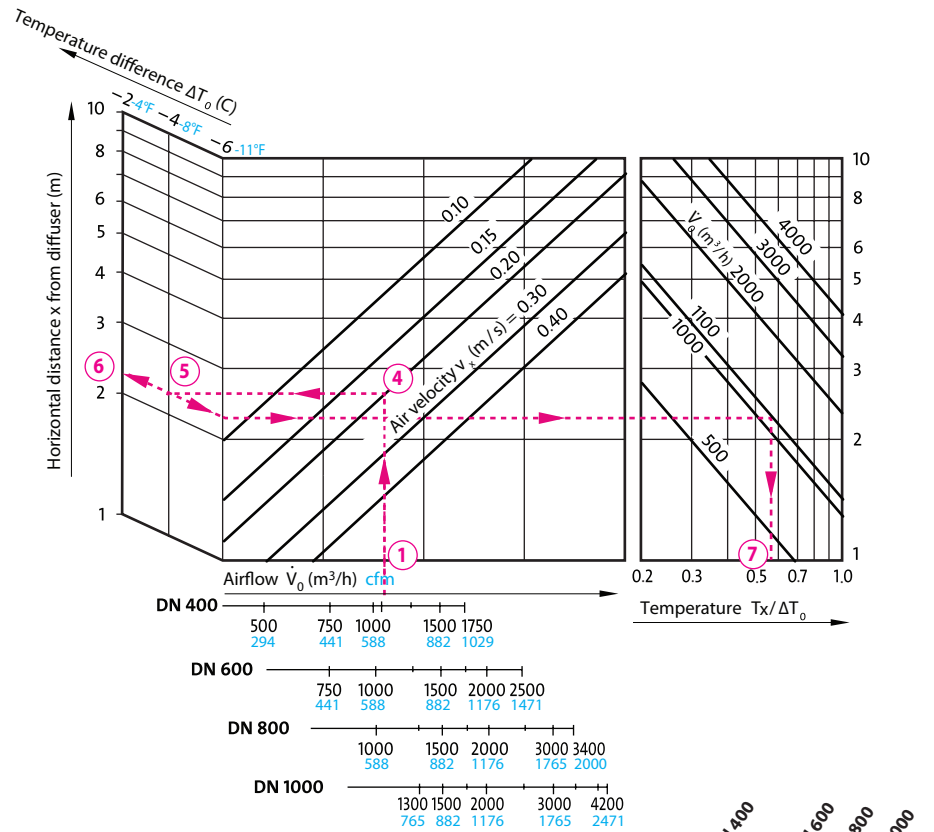

**Correction table**

	Height (mm)			
	750	1000	1250	1500
$v_x$	x 0.94	x 1.00	x 1.04	x 1.07
$\Delta T_x / \Delta T_0$	x 0.86	x 1.00	x 1.11	x 1.22
$\Delta p_t$	x 1.25	x 1.00	x 0.80	x 0.65
LWA (dB(A))	+3	± 0	-3	-6

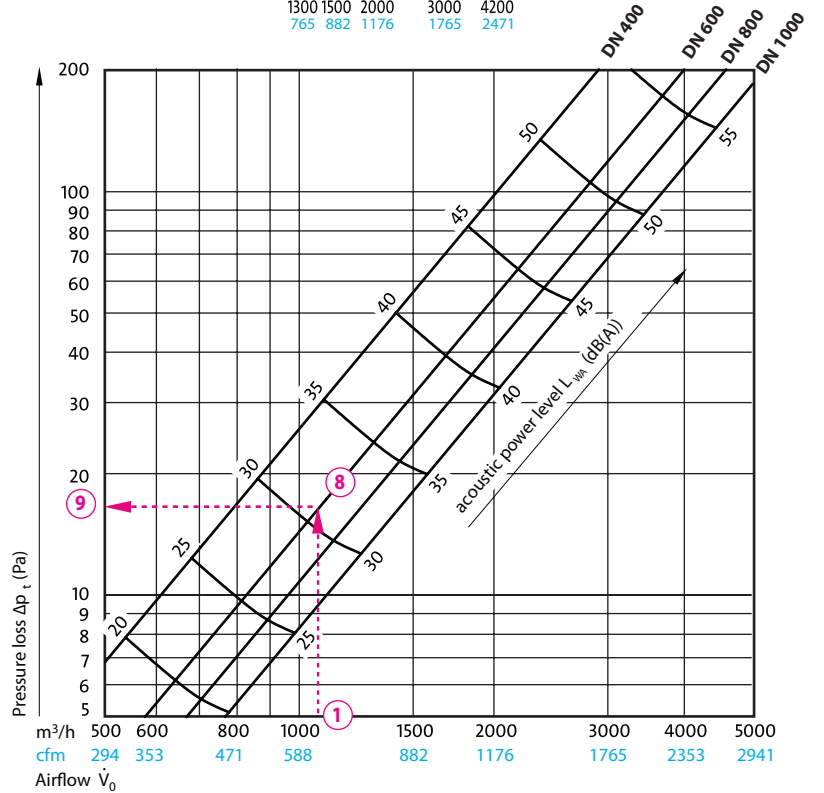

Areas of application, dimensions and aerodynamic data

QAL - H

Semi-circular - 180° - wall installation

Areas of application

The 3 air volume flow ranges given for the individual designs, sizes and heights have been determined according to the charge velocities.

These discharge velocities relate to the displacement flow diffuser's overall surface (front panel).

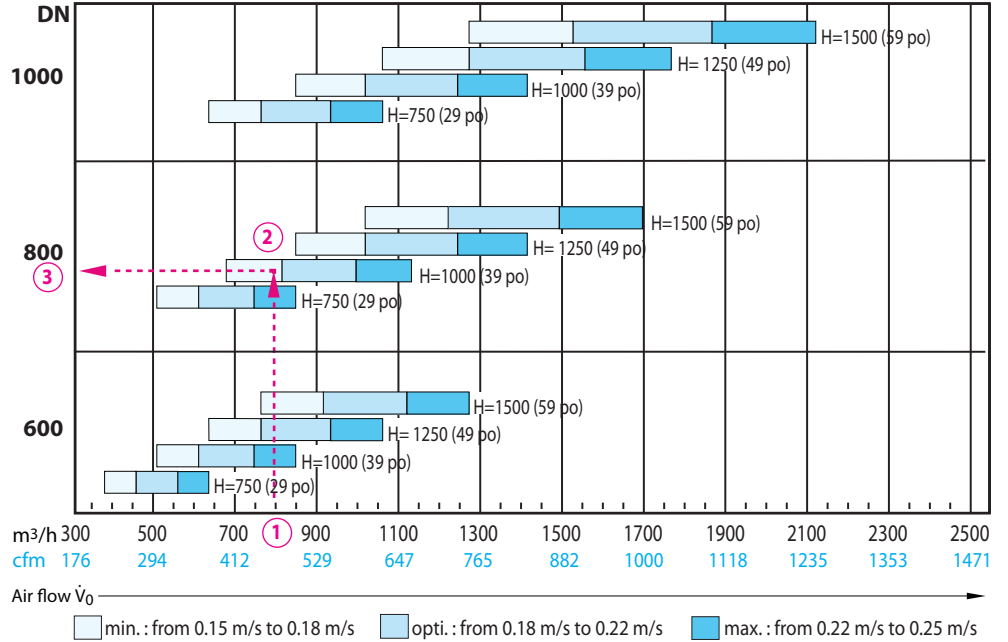
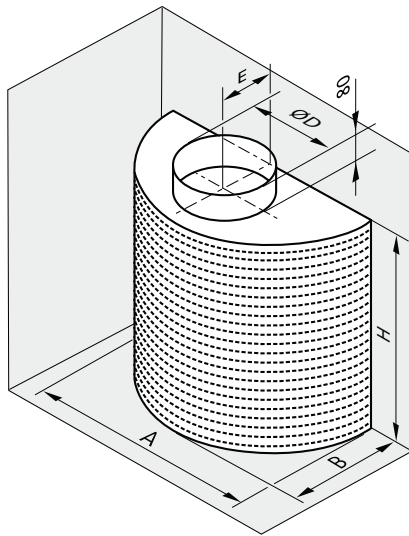

Aerodynamic data

Nominal size	Height (mm)	$\dot{V}_{min}$ (m³/h)	$\dot{V}_{max}$ (m³/h)	$\dot{V}_{nom.}$ (m³/h)	$\dot{V}_{nom.}$ $\Delta p$ (Pa)	$\dot{V}_{nom.}$ $L_{WA}$ dB(A)	$\dot{V}_{nom.}$ L (m)
DN 600	750	380	640	510	7	< 20	1.0
	1000	510	850	680	11	23	1.4
	1250	640	1060	850	14	25	1.7
	1500	760	1270	1020	16	26	2.0
DN 800	750	510	850	680	11	24	1.2
	1000	680	1130	900	15	27	1.6
	1250	850	1410	1130	18	29	1.9
	1500	1020	1700	1360	23	31	2.3
DN 1000	750	640	1060	850	13	26	1.3
	1000	850	1410	1130	16	27	1.8
	1250	1060	1770	1410	22	30	2.1
	1500	1270	2120	1700	25	32	2.5

$V_{min}$ : airflow for a velocity loss of 0.15 m/s  
 $V_{max}$ : airflow for a velocity loss of 0.25 m/s  
 $V_{nom}$ : Airflow for a velocity loss of 0.2 m/s  
 L: Horizontal distance of the diffuser for  $\Delta T_0 = -2^\circ C$   
 Then the airflow is:  $\leq 0.25$  m/s

Dimensions

	DN 600				DN 800				DN 1000			
Size A	610				813				1016			
Size B	381				406				508			
Size E	193				203				254			
Size ØD	200	200	250	250	200	250	250	300	250	250	300	300
Size H	750	1000	1250	1500	750	1000	1250	1500	750	1000	1250	1500

## Sizing diagrams QAL - H

**Example**
**Data**

Height: 1000 mm (39 in) **(2)**  
 Flow: 471 cfm 800 m<sup>3</sup>/h **(1)**  
 Temperature difference: -2°C **(5)**  
 Distance from the diffuser: 1.5 m (58.5 in) **(6)**

**Required**

DN:  $x: \Delta T_x / \Delta T_0: \Delta p_t: L_{WA}$

**Solution**

From the "Areas of application" diagram we find the DN 800. **(3)**

From the "Rating diagram", when applying the correction table, we find:

$v_x = 0.21 \times 1 = 0.21$  m/s **(4)**  
 $\Delta T_x / \Delta T_0 = 0.89 \times 1 = 0.89$  **(7)**  
 $\Delta p_t = 11 \times 1 = 11$  Pa **(9)**  
 $L_{WA} = 24 + 0 = 24$  dB **(8)**

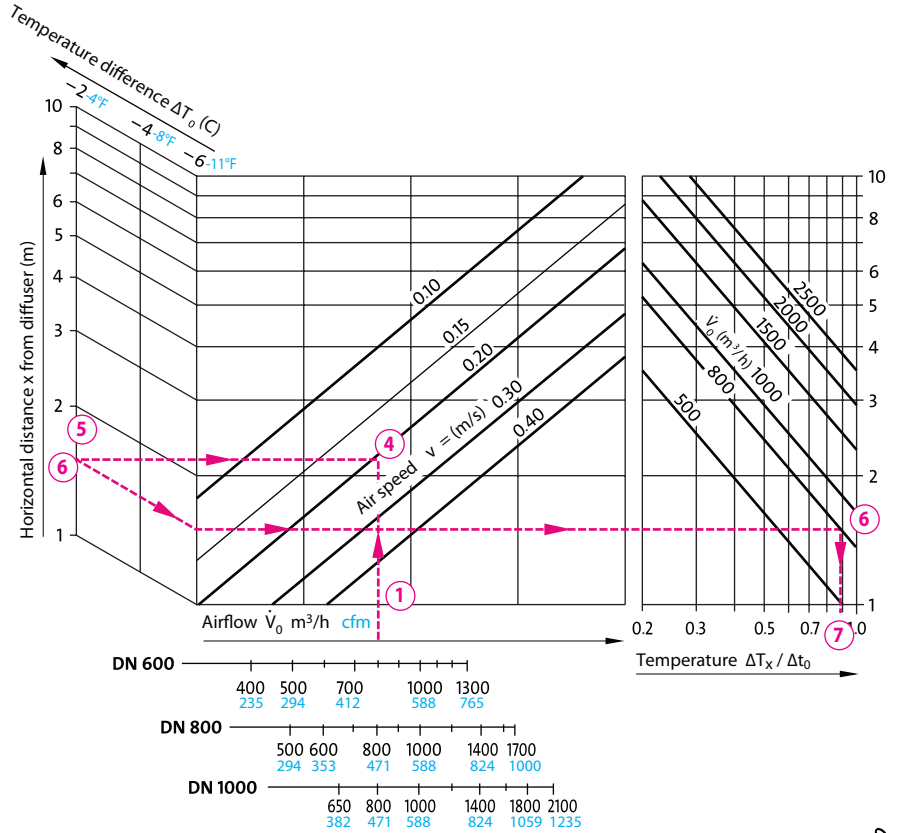
**Correction table**

	Height (mm)			
	750	1000	1250	1500
$v_x$	x 0.94	x 1.00	x 1.04	x 1.07
$\Delta T_x / \Delta T_0$	x 0.86	x 1.00	x 1.11	x 1.22
$\Delta p_t$	x 1.25	x 1.00	x 0.80	x 0.65
$L_{WA}$ (dB(A))	+3	± 0	-3	-6

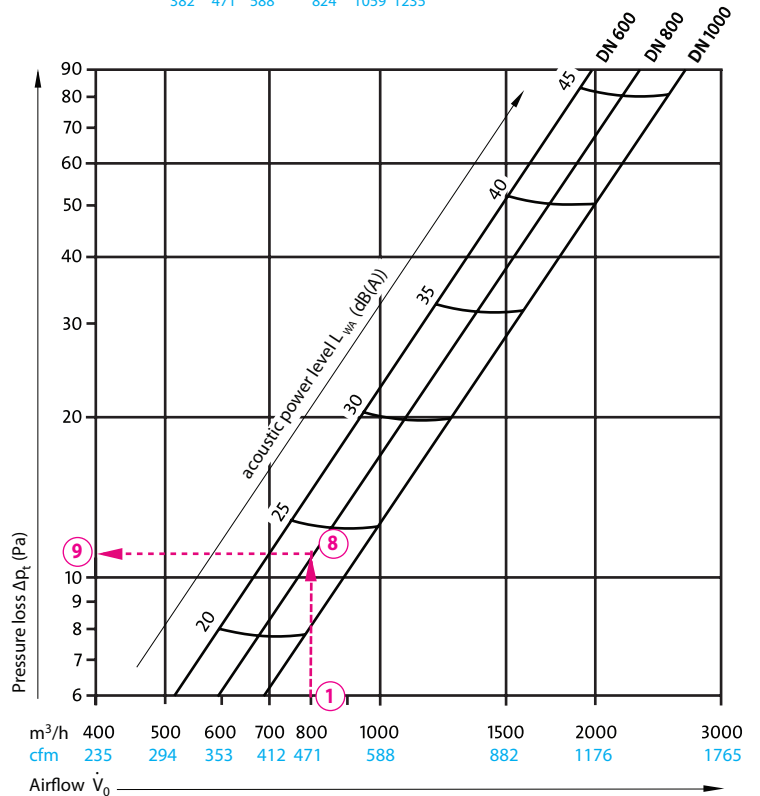

**Areas of application, dimensions and aerodynamic data**  
**QAL - V**

**Quarter circle 90°- corner installation**

**Areas of application**

The three ranges of airflow for the shape, the dimension and the height data are based on the speed of air exiting the diffuser.

These speeds represent the diffuser's total surface (at the frontal plate).

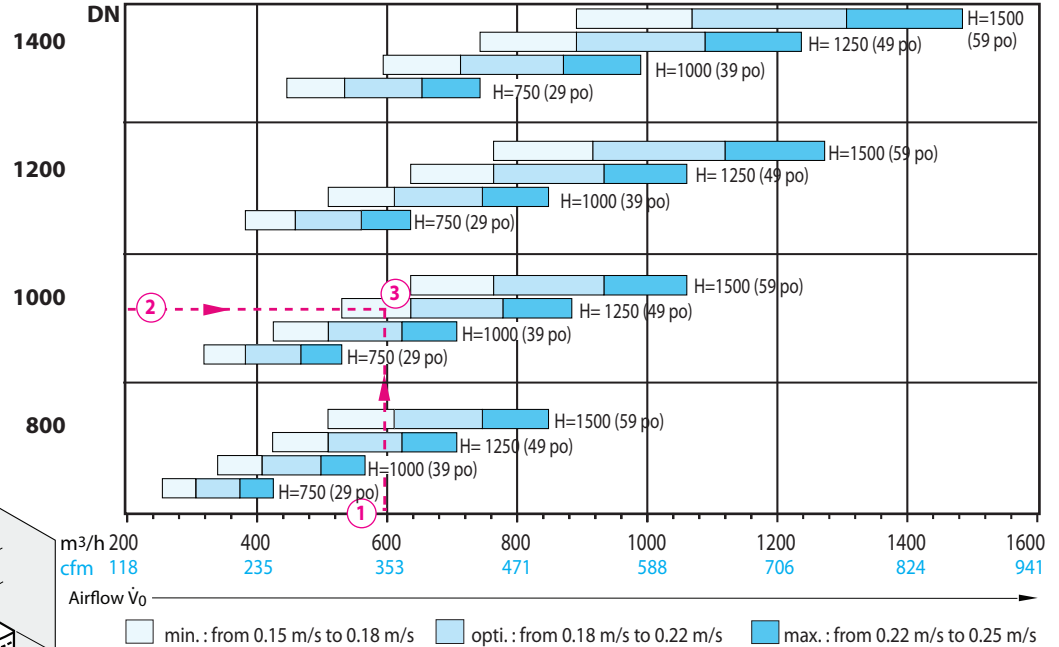
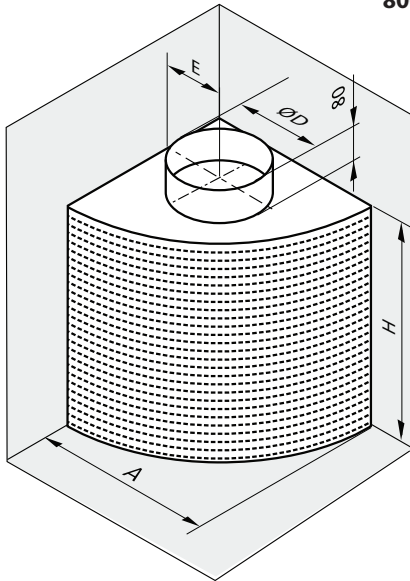

**Aerodynamic data**

	Height (mm)	$\dot{V}_{min}$ (m³/h)	$\dot{V}_{max}$ (m³/h)	$\dot{V}_{nom.}$ (m³/h)	$\dot{V}_{nom.}$ $\Delta p$ (Pa)	$\dot{V}_{nom.}$ $L_{WA}$ (dB(A))	$\dot{V}_{nom.}$ L (m)
DN 800	750	250	420	340	10	29	1.4
	1000	340	560	450	15	33	1.8
	1250	420	710	560	20	34	2.1
	1500	510	850	680	23	36	2.5
DN 1000	750	320	530	420	10	30	1.6
	1000	420	710	560	15	33	2.1
	1250	530	880	710	20	34	2.6
	1500	640	1060	850	23	37	3.0
DN 1200	750	380	640	510	11	33	1.7
	1000	510	850	680	18	37	2.2
	1250	640	1060	850	22	38	2.7
	1500	760	1270	1020	26	39	3.1
DN 1400	750	450	740	590	15	35	2.0
	1000	590	990	790	20	37	2.6
	1250	740	1240	990	25	39	3.1
	1500	890	1480	1190	30	41	3.6

$V_{min}$ : airflow for a velocity loss of 0.15 m/s  
 $V_{max}$ : airflow for a velocity loss of 0.25 m/s  
 $V_{nom}$ : Airflow for a velocity loss of 0.2 m/s  
 L: Horizontal distance of the diffuser for  $\Delta T_0 = -2^\circ C$ .  
 Then the airflow is:  $\leq 0.25$  m/s

**Dimensions**

	DN 800				DN 1000				DN 1200				DN 1400			
<b>Size A</b>	406				508				610				711			
<b>Size E</b>	203				254				305				356			
<b>Size ØD</b>	200	200	250	300	200	250	250	250	200	250	300	300	250	300	300	356
<b>Size H</b>	750	1000	1250	1500	750	1000	1250	1500	750	1000	1250	1500	750	1000	1250	1500

### Sizing diagrams QAL - V

**Example**
**Data**

DN: 1000 mm (39 in) **(2)**  
 Flow: 353 cfm 600 m<sup>3</sup>/h **(1)**  
 Temperature difference: -4°C **(5)**  
 Temperature ratio:  $\Delta T_x / \Delta T_0 = 0.3$  **(7)**

**Required**

Overall height:  $v_x$ ;  $x$ ;  $\Delta p_t$ ;  $L_{WA}$

**Solution**

From the "Areas of application" diagram we find a height of 1250 mm (58.5 in) **(3)**  
 From the "Sizing diagram", when applying the correction table, we find:  
 $v_x = 0.23 \times 1.04 = 0.24$  m/s **(4)**  
 $x = 2.9$  m **(6)**  
 $\Delta p_t = 15 \times 0.8 = 12$  Pa **(9)**  
 $L_{WA} = 35 - 3 = 32$  dB **(8)**

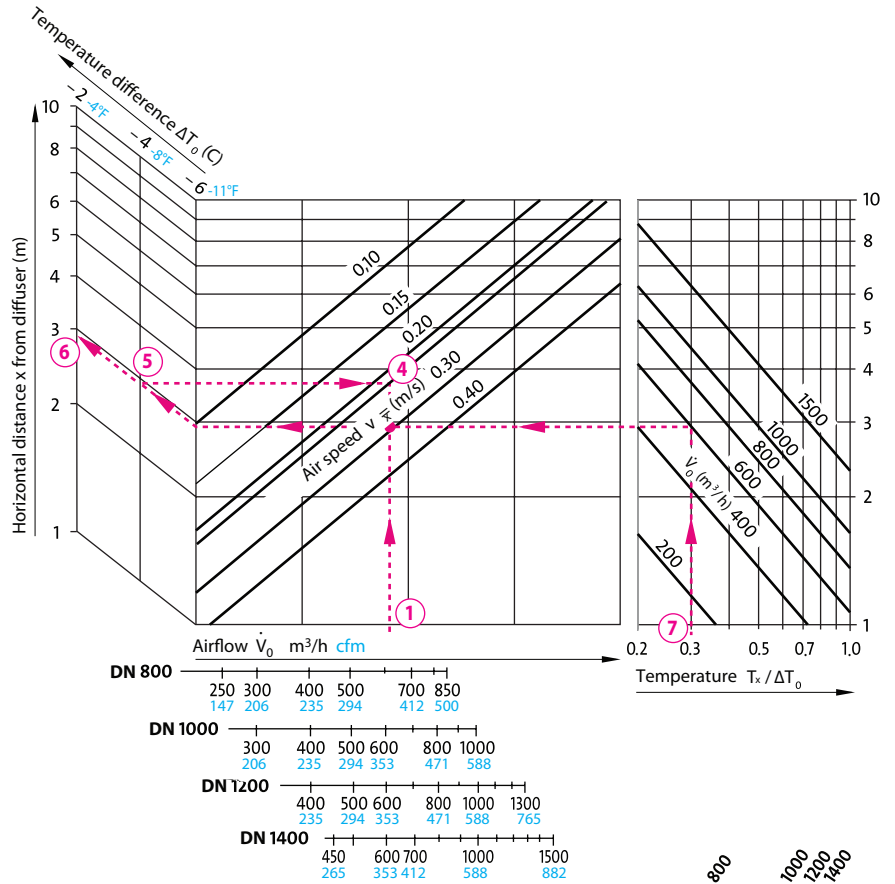
**Correction table**

	Height (mm)			
	750	1000	1250	1500
$v_x$	x 0.94	x 1.00	x 1.04	x 1.07
$\Delta T_x / \Delta T_0$	x 0.86	x 1.00	x 1.11	x 1.22
$\Delta p_t$	x 1.25	x 1.00	x 0.80	x 0.65
$L_{WA}$ [dB(A)]	+3	± 0	-3	-6

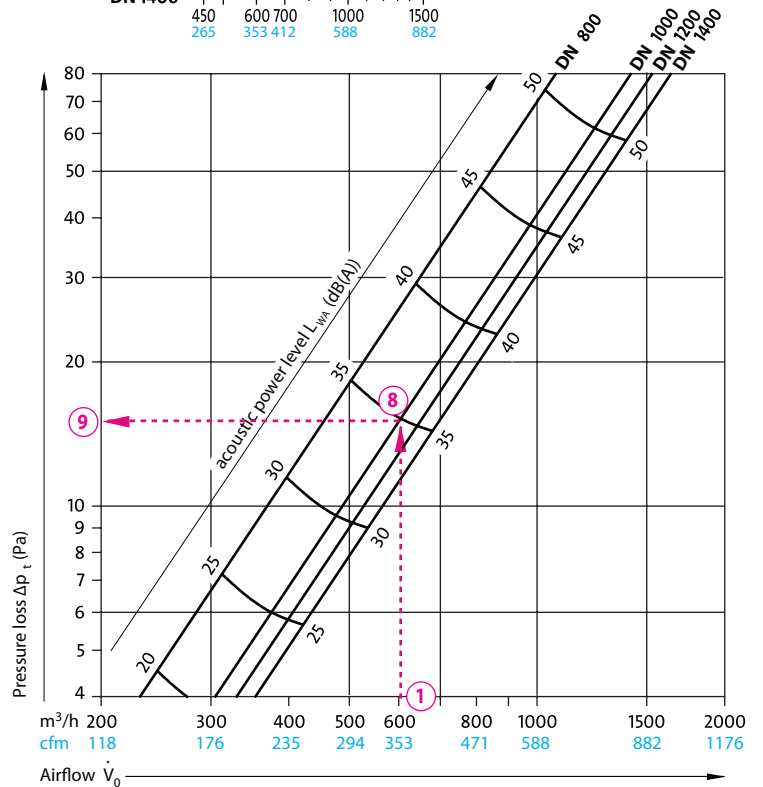

## Specifications

### QAL - L

#### 1- Description and physical characteristics

- 1.1 The linear air displacement diffuser, in a wall shall have a low airflow exit speed and low level of turbulence. It shall be composed of a perforated frontal plate made of galvanised steel, a 21% vested section and an integrated air dividing mechanism.
- 1.2 The upper and lower covering plates, as well as the side and rear walls, shall be made of galvanised steel. The diffuser's interior joints shall be sealed with silicon.
- 1.3 Each plate can be painted on the interior and the exterior with powder coated thermo-lacquered paint in the architect's choice of color from the RAL color chart.

#### 2- Performance

The performance of NAD Klima QAL – L diffusers shall be achieved with the help of the diagrams which indicating the loss of pressure, the acoustic power generated, the horizontal trajectory of the airflow as well as the initial and final temperature differential ratios in cooling mode.

#### 3- Connection

The connection shall be made with a sleeve placed at the diffuser's bottom or top.

#### 4- Quality required: NAD Klima QAL – L model

### QAL - R

#### 1- Description and physical characteristics

- 1.1 The round air displacement diffuser, shall have a low airflow exit speed and low level of turbulence. Freely mounted, it shall be composed of a perforated frontal plate made of galvanised steel, a 21% vested section and an integrated air dividing mechanism.
- 1.2 The covering upper and lower plates shall be made of galvanised steel. The diffuser's interior joints shall be sealed in silicon.
- 1.3 Each plate can be painted on the interior and exterior with powder coated thermo-lacquered paint in the architect's choice of color from the RAL color chart.

#### 2- Performance

The performance of NAD Klima QAL- R diffusers shall be achieved with the help of the diagrams indicating the loss of pressure, the acoustic power generated, the horizontal trajectory of the airflow as well as the initial and final temperature differential ratios in cooling mode.

#### 3- Connection

The connection shall be made with a sleeve placed at the diffuser's bottom or top.

#### 4- Quality required: NAD Klima QAL – R model.

### QAL - H

#### 1- Description and physical characteristics

- 1.1 The semi-circular air displacement diffuser, shall have a low airflow exit speed and low level of turbulence. Mounted in a wall, it shall be composed of a perforated frontal plate made of galvanised steel, a 21% vested section and an integrated air dividing mechanism.
- 1.2 The upper and lower covering plates, as well as the rear and side walls, shall be made of galvanised steel. The diffuser's interior joints shall be sealed with silicon.
- 1.3 Each plate can be painted on the interior and exterior with a powder coated paint in the architect's choice of color from the RAL color chart.

#### 2- Performance

The performance of NAD Klima QAL – H diffuser shall be achieved with the help of diagrams indicating the loss or pressure, the acoustic power generated, the horizontal trajectory of the airflow as well as the initial and final temperature differential ratios in cooling mode.

#### 3- Connection

The connection shall be made with a sleeve placed at the diffuser's bottom or top.

#### 4- Quality required: NAD Klima QAL – H model

### QAL - V

#### 1- Description and physical characteristics

- 1.1 The quarter-circular air displacement diffuser, shall have a low airflow exit speed and low level of turbulence. Mounted in a corner, it shall be composed of a perforated frontal plate made of galvanised steel, a 21% vested section and an integrated air dividing mechanism.
- 1.2 The upper and lower covering plates as well as the rear and side walls shall be made of galvanised steel. The diffuser's interior joints shall be sealed with silicon.
- 1.3 Each plate can be painted on the interior and exterior with a powder coated paint in the architect's choice of color from the RAL color chart.

#### 2- Performance

The performance of NAD Klima QAL – V diffusers shall be achieved with the help of diagrams indicating the loss or pressure, the acoustic power generated, the horizontal trajectory of the airflow as well as the initial and final temperature differential ratios in cooling mode.

#### 3- Connection

The connection shall be made with a sleeve placed at the diffuser's bottom or top.

#### 4- Quality required: NAD Klima QAL – V model.



## QAL

### Codification

QAL	Product
L = Linear – encased in a wall R = Round (360°) – floor installation H = Semi-circular (180°) – wall installation V = Quarter-circular (90°) – corner installation	<b>Configuration</b>
0400, 0600, 0800, 1000	<b>Nominal dimension</b> DN : - L, - R
0600, 0800, 1000	DN : - H
0800, 1000, 1200, 1400	DN : - V
0750, 1000, 1250, 1500	<b>Height</b>
9003 = White 9010 = Cream 00SB = Solar Black (standard matte black) 00SM = Silver Matte (standard metallic grey) ____ = RAL color (write the RAL color number)	<b>Diffuser color</b>
<b>QAL - L - 0400 - 0750 - 9003</b>	<b>Example</b>



# www.nadklima.com

**NAD Klima** (Head office)

144, rue Léger,  
Sherbrooke, QC, J1L 1L9 Canada  
T: 819 780-0111 • 1 866 531-1739  
F: 819 780-1660s  
info@nadklima.com

---

**NAD Klima Ontario**

2840, Argentia Road, Unit 6,  
Mississauga, ON, L5N 8G4 Canada  
T: 416-860-1067  
ontario@nadklima.com

