

SRA

Duct diffuser
catalog 1.1.4





Barrie, public Library, Ontario, Canada



SRA

Table of contents

Description, areas of application and benefits	1
Configuration	2
Operation and direction of air flow	3
Range of application	4
Selecting the size of the duct	5
Selecting the number of slots - with eccentric rollers	6
Selecting the number of slots - with nozzle rollers	7
Diagrams of performance	
Airflow velocity - with eccentric rollers	8
Airflow velocity - with nozzle rollers	9
Vertical deflection	10
Acoustic power	11
Table of equivalences and weight	12
Loss of pressure	13
Example of calculation	14
Installation	15
Specifications	16
Codification	17
Codification of the accessories	18, 19



Kitchen at Marie-Reine-des-coeurs, Montréal, Canada

Presentation and benefits

The SRA is a square or rectangular high induction diffuser, made to address the ventilation needs of spaces with low and medium heights.

The SRA diffuser is made of galvanized steel covered with powder coated paint. The standard manufacture size is 1500 mm (57 in) long. Alternatively, it is available in different lengths to meet your needs.

It is ideal for applications where technology must be not only efficient but also integrated into the architectural design.

With integrated eccentric rollers and/or nozzle rollers, the rectangular or square SRA diffuser offers a multitude of air direction possibilities.

All air conditioning and heating solutions are found in one application which combines technology, aesthetics and comfort.

Benefits

- High induction diffuser which allows homogeneity of the air in a room: the temperature, humidity and density.
- Increased comfort in the occupied zone
 - Comfortable air movement
 - Low temperature differences
 - Low noise
- Eccentric rollers allow an adjustment of the airflow in a 180° range
- Possibility of changing the direction of air flow after installation
- Possibility of reducing the total airflow up to 30% in VAV
- Possibility of eliminating heating baseboard through heating with the diffuser
- Simplify the ventilation network and reduce installation costs
- Easy adaption to systems with variable or constant airflow



Areas of application

- Commercial industry
- Ventilation of large areas
- Office areas
- Entry hall
- Industrial areas
- Agora

Easy to maintain

- Powder coated paint which minimizes dust collection and makes it easy to clean
- Low accumulation of dust in the duct because dust is purged by the slots

Durability

- The powder coated paint prevents chipping
- Steel suspension rail and duct in galvanized metal covered with a powder coated paint

Easy installation

- Installed using a suspension rail
- No sealing required
- Fewer suspension rods and installation screws

Configuration

Composition

The SRA diffuser is a smooth diffuser with rectangular sections, on which the slots are mounted lengthwise. The number of slots is determined by the amount of air flow and by the duct's dimensions.

The slots contain 100 mm long ABS eccentric rollers or ABS nozzle rollers (black or white). The SRA diffuser is available in many dimensions (see page 12).

The eccentric rollers are provided with alphanumeric guides, which allow adjustment of the airflow pattern across a 180° range.

Passive ducts without slots are available in the same dimensions as the active SRAs, in order to ensure the uniformity of the duct network.

Accessories

All of the standard accessories (elbows, sleeves, reducers, multi-branch connectors, etc.) are available in the precise dimensions of the ducts.

For air balancing reasons, reducers or a balancing damper are required between multiple sections.

Assembly

The sections of the SRA diffuser fit into one another and require no sleeves.

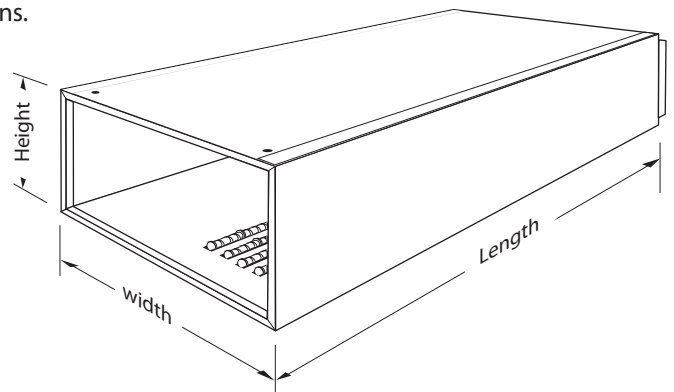

Accessories

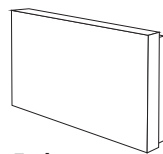

End cap

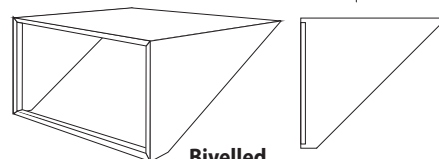

Bivelled end cap

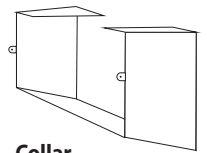

Collar

Branches

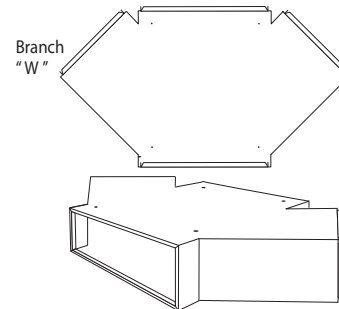
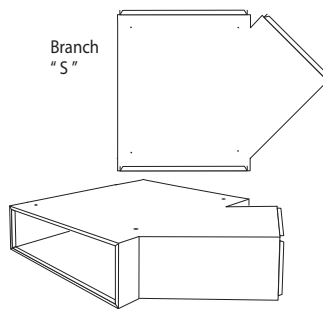
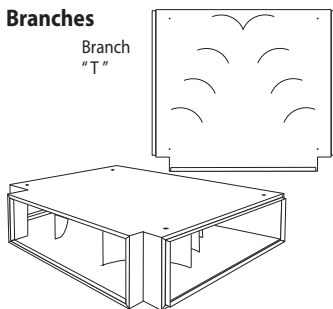

Detailed manufacturing of a transformation

Eccentric reducer - Flat on top / bottom

Orientation of the air flow

① $H/L = 1/4$

② $H/L = 1/7$

$$H = A - B$$

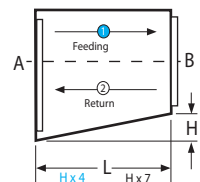

① $L = H \times 4$

② $L = H \times 7$

Reducer

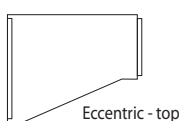
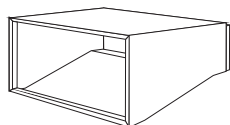

Eccentric - top

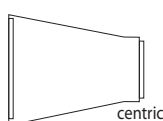

centric

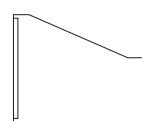

Eccentric - bottom

Centered reducer

Orientation of the air flow

① $H/L = 1/4$

② $H/L = 1/7$

$$H = (A - B) \div 2$$

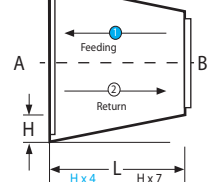

① $L = H \times 4$

② $L = H \times 7$

Elbows

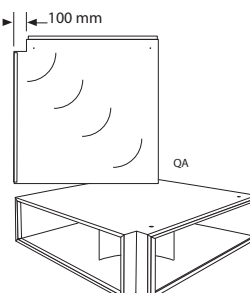
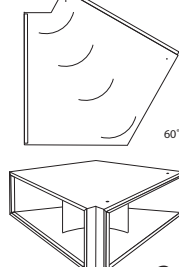
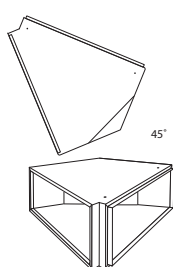
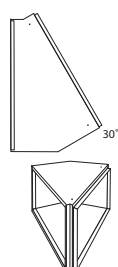
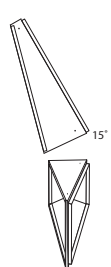

QA

Note: The standard length of reducers is rounded to the next whole foot
ex.: $L = 1.3 \text{ ft}$ will be: $L = 2 \text{ ft}$

Mode of operation and direction of air flow

Mode of operation

The eccentric rollers and nozzle rollers form, combined with aluminum air guiding slots, an optimal flow of air. A drop in pressure occurs when approaching the rollers' surface. As air leaves the slot, it is stable and generates a low level of acoustic power. The flow maintains a powerful induction of ambient air. The eccentric rollers' positioning allows for an air jet direction adjustment, with or without reduction in the exit area. The rollers have small plates to guide the air, which support a dense airflow and maintain the direction of the air flow perpendicular to the rollers' axis.

Setting of the air jet direction

Thanks to the shape of the eccentric rollers and adjustment dial with alphanumeric characters, air jet's direction at the diffuser's outlet can vary up to 180°. For each direction, there are two (2) roller positions ("reduced" or "not reduced"), as illustrated in figure E.

The length of each roller is 100 mm and they are individually adjustable. As a result, the combinations of airflow are almost infinite. In manufacturing, the ducts are individually adjusted for each project. The standard setting for the rollers is set to diffusion mode in positions "21" and "65" alternately. This setting produces strong induction, which can be used to meet heating and cooling needs, thereby creating high mixing levels. The nozzle rollers can only be set in the open and closed position.

As a result, the divergent mode allows of the air jets to blow in more accurate directions.

This mode also allows a longer projection of the airflow. In specific zones, which are usually difficult to cover, a specialized setting can be created. Figures C and D show the relationship between the position of the eccentric roller and the direction of exiting airflow. Note that to maximize air projection, multiple jets can be orientated in the same direction to optimize the coverage of a zone, even when heating.

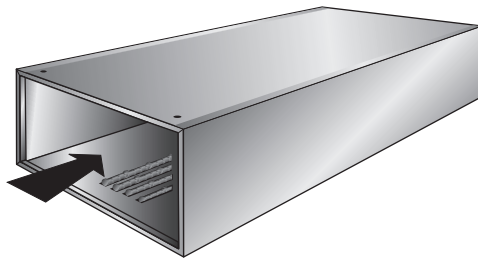
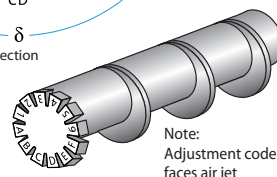
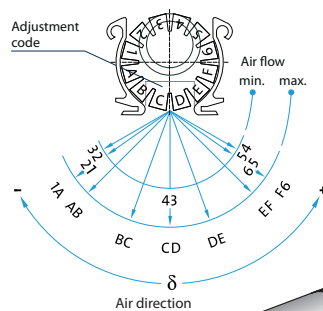
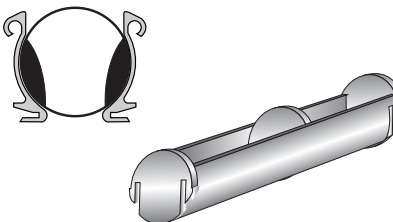

Figure E

Eccentric roller



Nozzle roller (DRB)



Eccentric roller



Nozzle roller

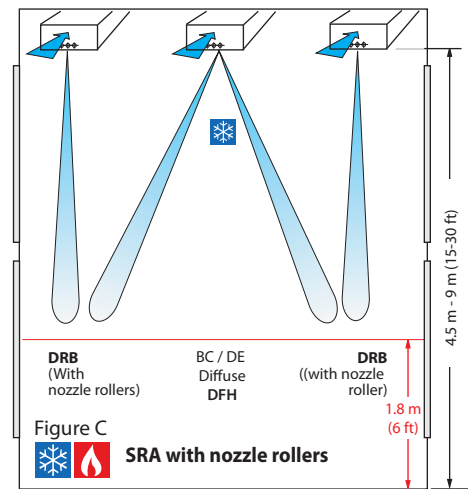
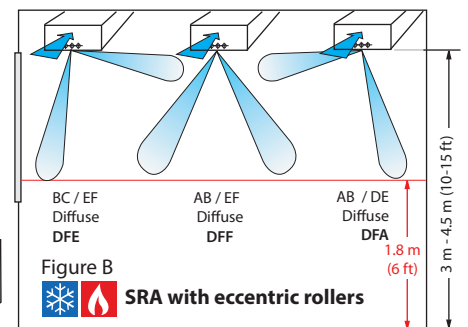
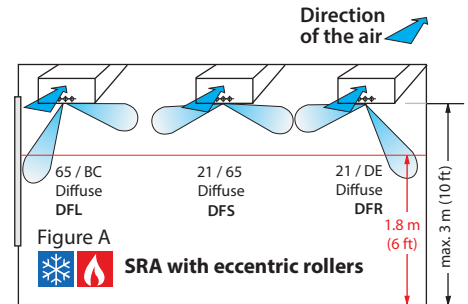

Slots at + 90°

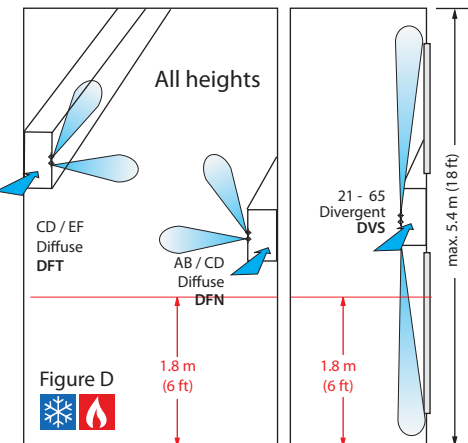

Range of application

Maximum installation space

	Air flow by meter of slot of SRA \dot{V}_0	Installation height of the SRA H	Recommended space between SRA X MAXIMUM
	m ³ /h/m (pcm/li ft)	m (ft)	m (ft)
	50 - 100 (9 - 19)	≤ 3 (10)	5 (16)
	100 - 150 (19 - 27)	3 - 4.3 (10 - 14)	7 (22)
	150 - 170 (27 - 31)	4.3 - 7 (14 - 23)	8 (26)

Cooling only: keep the maximum distance X depending on the height, but keep the airflow by meter of the slot at 50 – 120 m³/h/m.

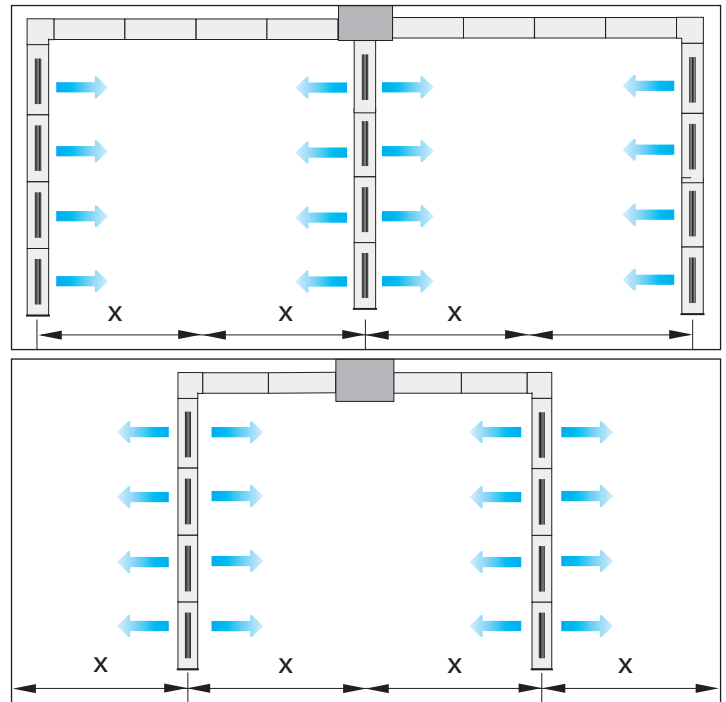

Aerodynamic balancing and reducer placement

To optimize a uniform airflow in the SRA diffuser, the total length must not exceed 7.5 meters (25 ft) without using a reducer or a balancing damper.

For a diffuser greater than 7.5 meters (25 ft), a reducer must be installed at the center (see 1) or, to keep the same dimensions of the duct, replaced with a balancing key (see 2).

Once there are more than 4.5 meters (15 ft) of active ducts, it is recommended to install a register for air balancing (see 3).

Reducer and register emplacement

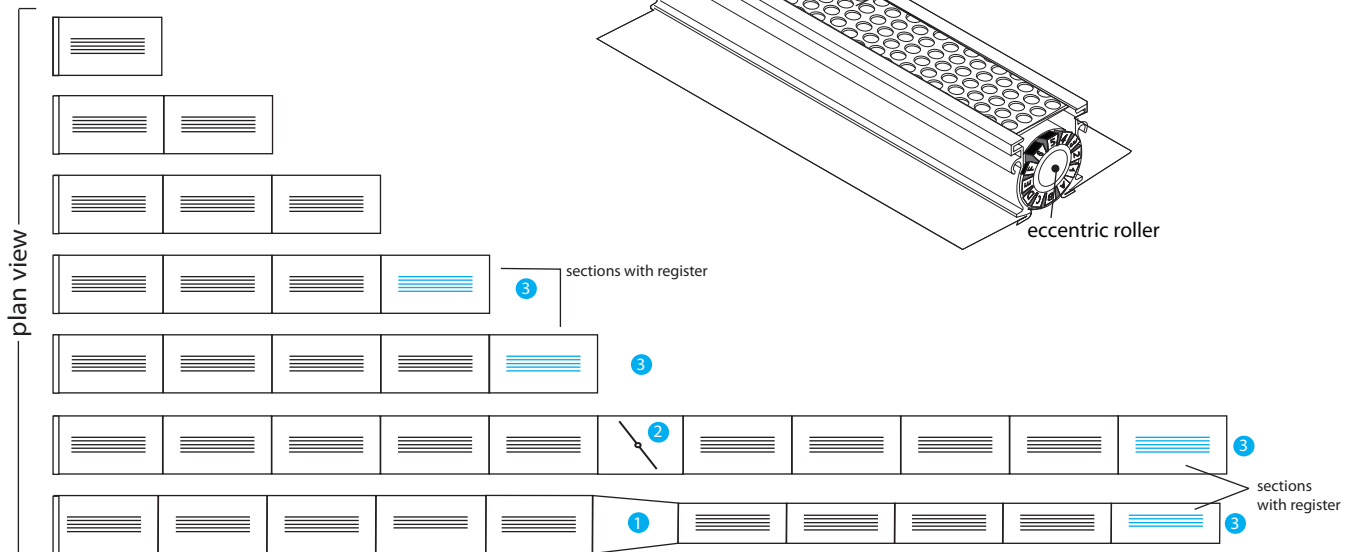



SRA

Selecting the size of the duct

CFM - Maximum flow

Width in mm	6	8	10	12	14	16	18	20	22	24	26	28	30	32	34	36	38	40	42	44	46	48	
	152	203	254	305	356	406	457	508	559	610	660	711	762	813	864	914	965	1016	1067	1118	1168	1219	
6	152	N/A	70	110	170	170	240	240	N/A	N/A	N/A	N/A	N/A	N/A	N/A	N/A	N/A	N/A	N/A	N/A	N/A	N/A	N/A
8	203	70	170	240	240	320	420	420	540	540	700	N/A	N/A	N/A	N/A	N/A	N/A	N/A	N/A	N/A	N/A	N/A	N/A
10	254	110	240	320	420	540	540	700	850	850	1000	1200	1200	1400	N/A	N/A	N/A	N/A	N/A	N/A	N/A	N/A	N/A
12	305	170	240	420	540	700	850	1000	1200	1200	1400	1500	1500	1700	1700	1900	1900	N/A	N/A	N/A	N/A	N/A	N/A
14	356	170	320	540	700	850	1000	1200	1400	1500	1700	1700	1900	2100	2100	2300	2300	2500	2500	2700	N/A	N/A	N/A
16	406	240	420	540	850	1000	1200	1400	1500	1700	1900	2100	2300	2300	2500	2700	2700	3000	3000	3200	3600	3600	3800
18	457	240	420	700	1000	1200	1400	1500	1900	2100	2100	2300	2500	2700	3000	3000	3200	3600	3600	3800	4000	4000	4400
20	508	N/A	540	850	1200	1400	1500	1900	2100	2300	2500	2700	3000	3000	3200	3600	3800	3800	4000	4400	4400	4800	5000
22	559	N/A	540	850	1200	1500	1700	2100	2300	2500	2700	3000	3200	3600	3800	3800	4000	4400	4800	4800	5000	5400	5400
24	610	N/A	700	1000	1400	1700	1900	2100	2500	2700	3000	3200	3600	3800	4000	4400	4800	5000	5400	5400	5600	6000	6000
26	660	N/A	N/A	1200	1500	1700	2100	2300	2700	3000	3200	3600	3800	4000	4400	4800	5000	5400	5600	6000	6000	6500	6800
28	711	N/A	N/A	1200	1500	1900	2300	2500	3000	3200	3600	3800	4000	4400	5000	5000	5400	5600	6000	6500	6800	7000	7000
30	762	N/A	N/A	1400	1700	2100	2300	2700	3000	3600	3800	4000	4400	5000	5400	5600	6000	6500	6800	6800	7000	7500	8000
32	813	N/A	N/A	N/A	1700	2100	2500	3000	3200	3800	4000	4400	5000	5400	5600	6000	6500	6800	7000	7500	8000	8500	8500
34	864	N/A	N/A	N/A	1900	2300	2700	3000	3600	3800	4400	4800	5000	5600	6000	6500	6800	7000	7500	8000	8500	9000	9400
36	914	N/A	N/A	N/A	1900	2300	2700	3200	3800	4000	4800	5000	5400	6000	6500	6800	7000	7500	8000	8500	9000	9400	9700
38	965	N/A	N/A	N/A	N/A	2500	3000	3600	3800	4400	5000	5400	5600	6500	6800	7000	7500	8000	8500	9000	9400	9700	10700
40	1016	N/A	N/A	N/A	N/A	2500	3000	3600	4000	4800	5000	5600	6000	6800	7000	7500	8000	8500	9400	9700	10700	11000	11100
42	1067	N/A	N/A	N/A	N/A	2700	3200	3800	4400	4800	5400	6000	6500	6800	7500	8000	8500	9000	9700	10700	11000	11100	11600
44	1118	N/A	N/A	N/A	N/A	N/A	3600	4000	4400	5000	5600	6000	6800	7000	8000	8500	9000	9400	10700	11000	11100	11600	12000
46	1168	N/A	N/A	N/A	N/A	N/A	3600	4000	4800	5400	6000	6500	7000	7500	8500	9000	9400	9700	11000	11100	11600	12000	12800
48	1219	N/A	N/A	N/A	N/A	N/A	3800	4400	5000	5400	6000	6800	7000	8000	8500	9400	9700	10700	11100	11600	12000	12800	13000

Liter / second - Maximum flow

Width in mm	6	8	10	12	14	16	18	20	22	24	26	28	30	32	34	36	38	40	42	44	46	48	
	152	203	254	305	356	406	457	508	559	610	660	711	762	813	864	914	965	1016	1067	1118	1168	1219	
6	152	N/A	33	52	80	80	113	113	N/A	N/A	N/A	N/A	N/A	N/A	N/A	N/A	N/A	N/A	N/A	N/A	N/A	N/A	N/A
8	203	33	80	113	113	151	198	198	255	255	330	N/A	N/A	N/A	N/A	N/A	N/A	N/A	N/A	N/A	N/A	N/A	N/A
10	254	52	113	151	198	255	255	330	401	401	472	566	566	660	N/A	N/A	N/A	N/A	N/A	N/A	N/A	N/A	N/A
12	305	80	113	198	255	330	401	472	566	566	660	708	708	802	802	896	896	N/A	N/A	N/A	N/A	N/A	N/A
14	356	80	151	255	330	401	472	566	660	708	802	802	896	991	991	1085	1085	1179	1179	1274	N/A	N/A	N/A
16	406	113	198	255	401	472	566	660	708	802	896	991	1085	1085	1179	1274	1274	1415	1415	1509	1698	1698	1792
18	457	113	198	330	472	566	660	708	896	991	991	1085	1179	1274	1415	1415	1509	1698	1698	1792	1887	1887	2075
20	508	N/A	255	401	566	660	708	896	991	1085	1179	1274	1415	1415	1509	1698	1792	1792	1887	2075	2075	2264	2358
22	559	N/A	255	401	566	708	802	991	1085	1179	1274	1415	1509	1698	1792	1792	1887	2075	2264	2264	2358	2547	2547
24	610	N/A	330	472	660	802	896	991	1179	1274	1415	1509	1698	1792	1887	2075	2264	2358	2358	2547	2642	2830	2830
26	660	N/A	N/A	566	708	802	991	1085	1274	1415	1509	1698	1792	1887	2075	2264	2358	2547	2642	2830	2830	3066	3208
28	711	N/A	N/A	566	708	896	1085	1179	1415	1509	1698	1792	1887	2075	2358	2358	2547	2642	2830	3066	3208	3302	3302
30	762	N/A	N/A	660	802	991	1085	1274	1415	1698	1792	1887	2075	2358	2547	2642	2830	3066	3208	3208	3302	3538	3774
32	813	N/A	N/A	N/A	802	991	1179	1415	1509	1792	1887	2075	2358	2547	2642	2830	3066	3208	3302	3538	3774	4009	4009
34	864	N/A	N/A	N/A	896	1085	1274	1415	1698	1792	2075	2264	2358	2642	2830	3066	3208	3302	3538	3774	4009	4245	4434
36	914	N/A	N/A	N/A	896	1085	1274	1509	1792	1887	2264	2358	2547	2830	3066	3208	3302	3538	3774	4009	4245	4434	4575
38	965	N/A	N/A	N/A	N/A	1179	1415	1698	1792	2075	2358	2547	2642	3066	3208	3302	3538	3774	4009	4245	4434	4575	5047
40	1016	N/A	N/A	N/A	N/A	1179	1415	1698	1887	2264	2358	2642	2830	3208	3302	3538	3774	4009	4434	4575	5047	5189	5236
42	1067	N/A	N/A	N/A	N/A	1274	1509	1792	2075	2264	2547	2830	3066	3208	3538	3774	4009	4245	4575	5047	5189	5236	5472
44	1118	N/A	N/A	N/A	N/A	N/A	1698	1887	2075	2358	2642	2830	3208	3302	3774	4009	4245	4434	5047	5189	5236	5472	5660
46	1168	N/A	N/A	N/A	N/A	N/A	1698	1887	2264	2547	2830	3066	3302	3538	4009	4245	4434	4575	5189	5236	5472	5660	6038
48	1219	N/A	N/A	N/A	N/A	N/A	1792	2075	2358	2547	2830	3208	3302	3774	4009	4434	4575	5047	5236	5472	5660	6038	6132

Selection of the number of slots

SRA with eccentric rollers

For an installation height up to 4.3 m (14 ft)

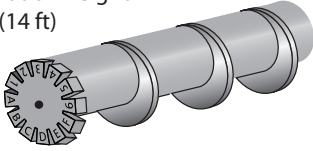

Important:

To make the selection of SRA, the total airflow must be calculated for a 1 m length of active slots.

Specifications:

Height at the bottom of the duct: $H = 4\text{ m}$
 Airflow by diffuser: $\dot{V}_0 = 420\text{ m}^3/\text{h}$
 Cooling: $\Delta T = -10^\circ\text{C}$
 Heating: $\Delta T = +10^\circ\text{C}$
 Length of the SRA: $L_R = 1500\text{ mm}$

Required:

- 1- Airflow per meter of slot section
- 2- Number of slots n

Solution:

- 1- The length of SRA slot is determined by the following:

$$L_S = L_R - 150\text{ mm} = 1300\text{ mm}$$

We find the airflow by meter of slot section:

$$\dot{V}_0 (\text{m}^3/\text{h RRA}) \times F = \dot{V}_0 (\text{m}^3/\text{h/m})$$

$$420 (\text{m}^3/\text{h}) \times 0.77 = 323 (\text{m}^3/\text{h/m}) \quad \textcircled{1}$$

- 2- Using the diagram "Selecting the number of slots", for a height of 4 m and with a heating application, we find the number of slots: $n = 3 \quad \textcircled{2}$

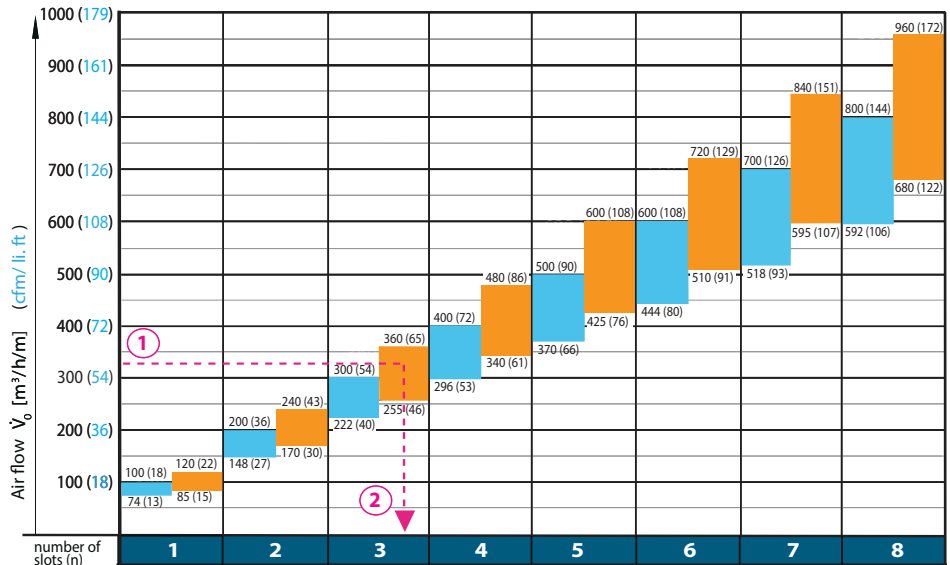

Air Flow by meter of slot of RRA \dot{V}_0		$\text{m}^3/\text{h/m/slot}$ (cfm/li.ft/slot)
■	Cooling only for all heights	74 - 100 (13 - 18)
■	Heating and cooling for heights $\leq 3.0\text{ m}$ (10 ft)	74 - 100 (13 - 18)
■	Heating and cooling or heating only for heights of 3.0 m (10 ft) – 4.3 m (14 ft)	85 - 120 (15 - 21)

- In the case where heating mode can not be selected with the initial air flow, reduce the slot length L_S in accordance with the recommended air flow per meter of slot.
- In a critical acoustic environment, increase the number of slots.

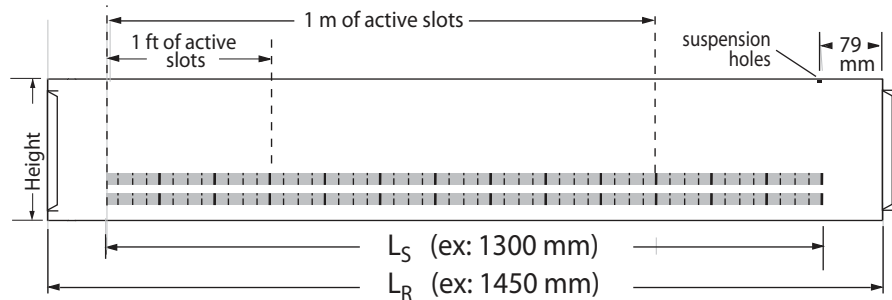

Calculating the number of slots

Width	Maximum number of slots	Width	Maximum number of slots
in (mm)	from 1 to ...	in (mm)	from 1 to ...
6 (152)	2	28 (711)	14
8 (203)	3	30 (762)	14
10 (254)	5	32 (813)	14
12 (305)	6	34 (864)	14
14 (356)	8	36 (914)	14
16 (406)	10	38 (965)	14
18 (457)	11	40 (1016)	14
20 (508)	13	42 (1067)	14
22 (559)	14	44 (1118)	14
24 (610)	14	46 (1168)	14
26 (660)	14	48 (1219)	14

Airflow conversion by meter of slot length

$$\dot{V}_0 (\text{m}^3/\text{h/m/SRA}) \times F = \dot{V}_0 (\text{m}^3/\text{h/m})$$

$$\dot{V}_0 (\text{cfm/SRA}) \times F = \dot{V}_0 (\text{cfm/li. ft})$$

Length of the RRA L_R	Slot length L_S (Li.ft)	Multiplication factor F
1000	800 (2.62)	1.25 (0.382)
1100	900 (2.95)	1.11 (0.339)
1200	1000 (3.28)	1.00 (0.305)
1300	1100 (3.60)	0.91 (0.278)
1400	1200 (3.94)	0.83 (0.254)
Standard	1450 (4.27)	0.77 (0.235)

Selection of the number of slots

SRA with nozzle roller

For an installation height from 4.3 m (14 ft) to 7 m (30 ft)

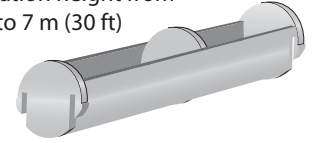

Important:

To facilitate the selection of the SRA, the total airflow should be calculated for active vent lengths of 1 m.

Specifications:

Height at the bottom of the duct: $H = 4\text{ m}$
 Airflow by diffuser: $\dot{V}_0 = 1040\text{ m}^3/\text{h}$
 Heating: $\Delta T = +10^\circ\text{C}$
 Length of the SRA: $L_R = 1500\text{ mm}$

Required:

- 1- Airflow per metre of slot section
- 2- Number of slots n

Solution:

- 1- The length of the SRA slot is determined by the following:

$$L_S = L_R - 200\text{ mm} = 1300\text{ mm}$$

The airflow is calculated by number of slot sections.

$$\dot{V}_0 (\text{m}^3/\text{h SRA}) \times F = \dot{V}_0 (\text{m}^3/\text{h/m})$$

$$1040 (\text{m}^3/\text{h}) \times 0.77 = 800 (\text{m}^3/\text{h/m}) \quad \textcircled{1}$$

- 2- From the diagram "Selecting the number of slots" and for a height of 5 m in heating application, we find the number of slots: $n = 3 \quad \textcircled{2}$

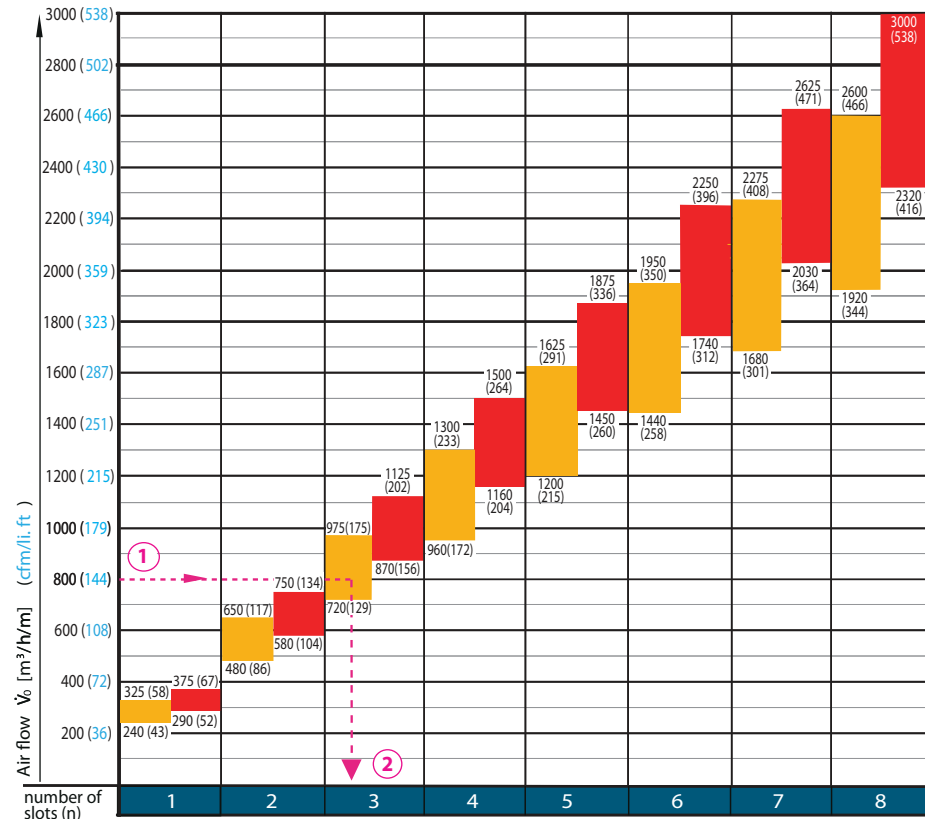

Air Flow by meter of slot of the RRA \dot{V}_0		$\text{m}^3/\text{h}/\text{m}/\text{slot}$ ($\text{cfm}/\text{li. ft}/\text{slot}$)
■	Heating only for ceiling heights of 4.3 m (14 ft) - 6.1 m (20 ft)	240 - 325 (43 - 58)
■	Heating only for ceiling heights of 6.1 m (20 ft) - 9 m (30 ft)	290 - 375 (52 - 67)

- In the case where heating mode can not be selected with the initial air flow, reduce the slot length L_S in accordance with the recommended air flow per meter of slot.
- In a critical acoustic environment, increase the number of slots.

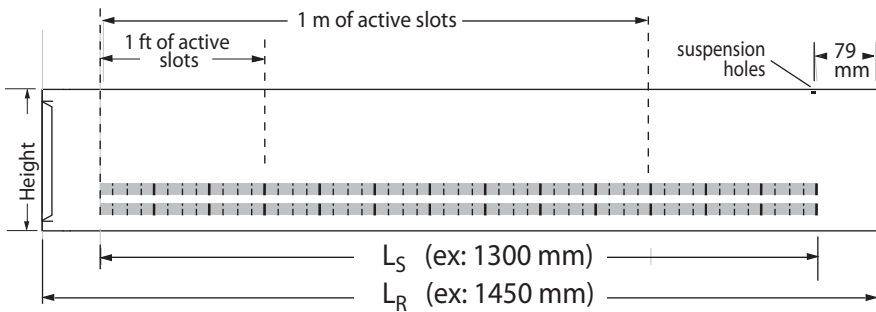

Airflow conversion by meter of slot length

$$\dot{V}_0 (\text{m}^3/\text{h}/\text{m}/\text{SRA}) \times F = \dot{V}_0 (\text{m}^3/\text{h}/\text{m})$$

$$\dot{V}_0 (\text{cfm}/\text{SRA}) \times F = \dot{V}_0 (\text{cfm}/\text{li. ft})$$

Length of the RRA L_R	Slot length L_S mm (li. ft)	Multiplication factor F
1000	800 (2.62)	1.25 (0.382)
1100	900 (2.95)	1.11 (0.339)
1200	1000 (3.28)	1.00 (0.305)
1300	1100 (3.60)	0.91 (0.278)
1400	1200 (3.94)	0.83 (0.254)
Standard	1450 1300 (4.27)	0.77 (0.235)

Air flow velocity diagrams

SRA with eccentric rollers

For an installation height from 3 m (10 ft) to 4.3 m (14 ft)

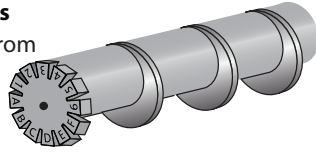

Airstream pattern (roller position)

$$V_{max} = k1 \times V_{max \text{ diagram}}$$

Diffuse

(1 x 21 / 1 x 65) standard

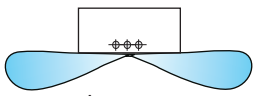

$k1 = 1.0$

Path after impact y

9.8 8.2 6.6 4.9 3.3 1.6
3 2.5 2 1.5 1 0.5 0 m

Divergence

(half left 21 - half right 65)

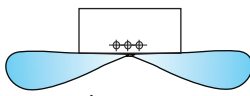

$k1 = 1.1$

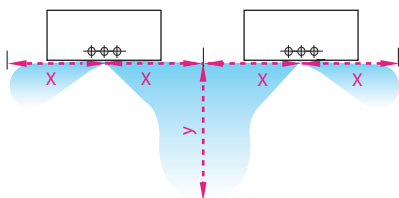
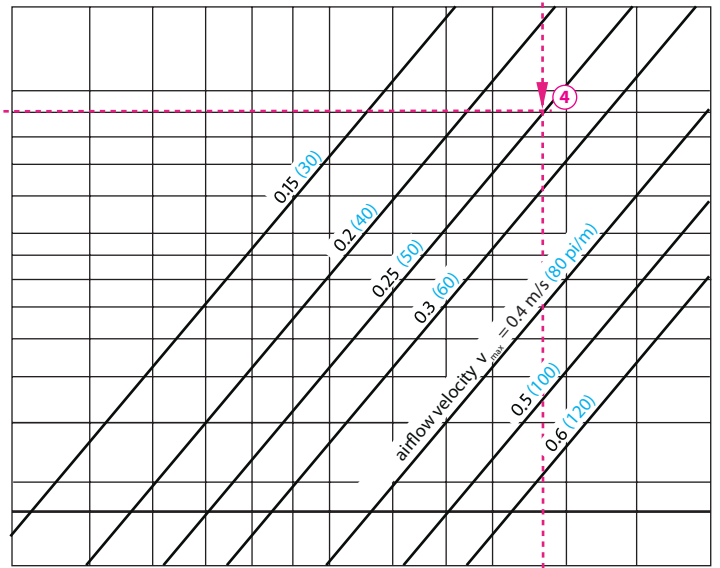
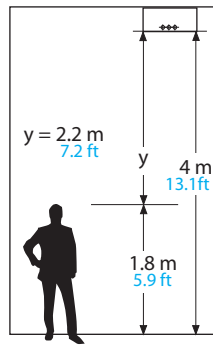
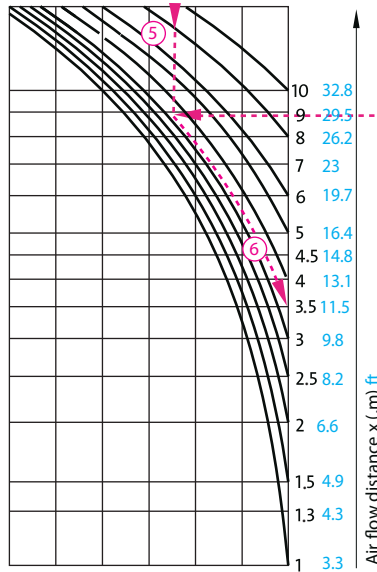
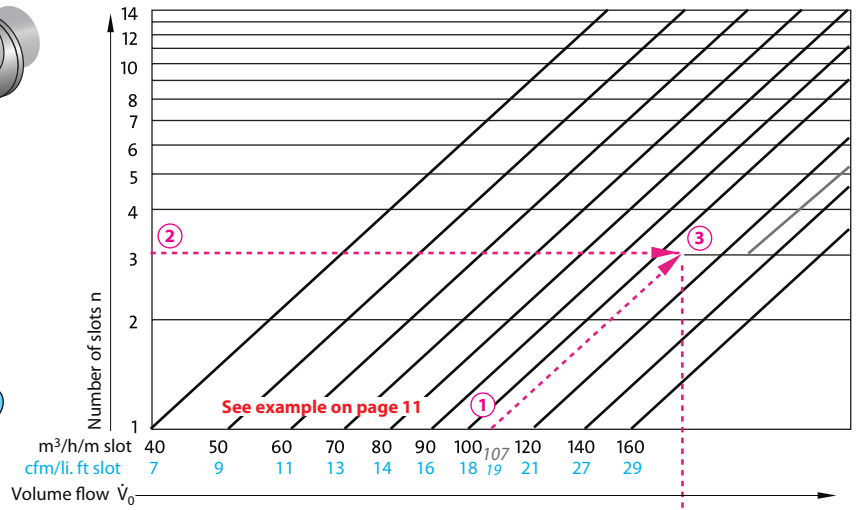

Vertical (All CD)

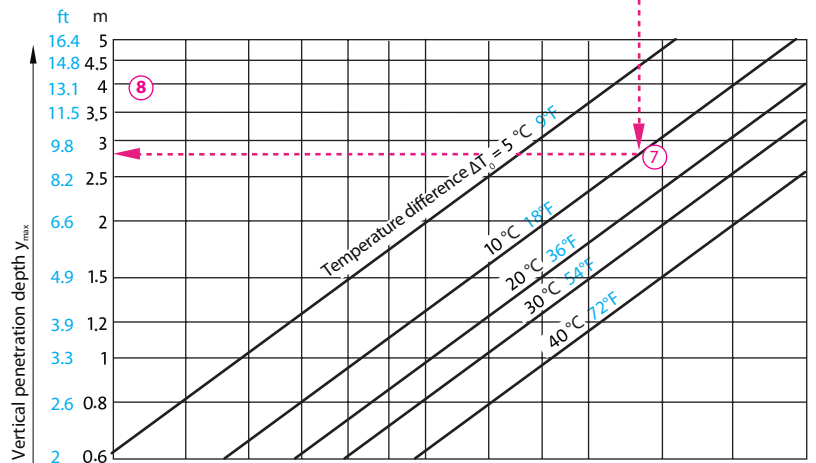
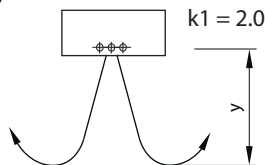

Air velocity diagrams

SRA with nozzle roller

For an installation height from 4.3 m (14 ft) to 9 m (30 ft)

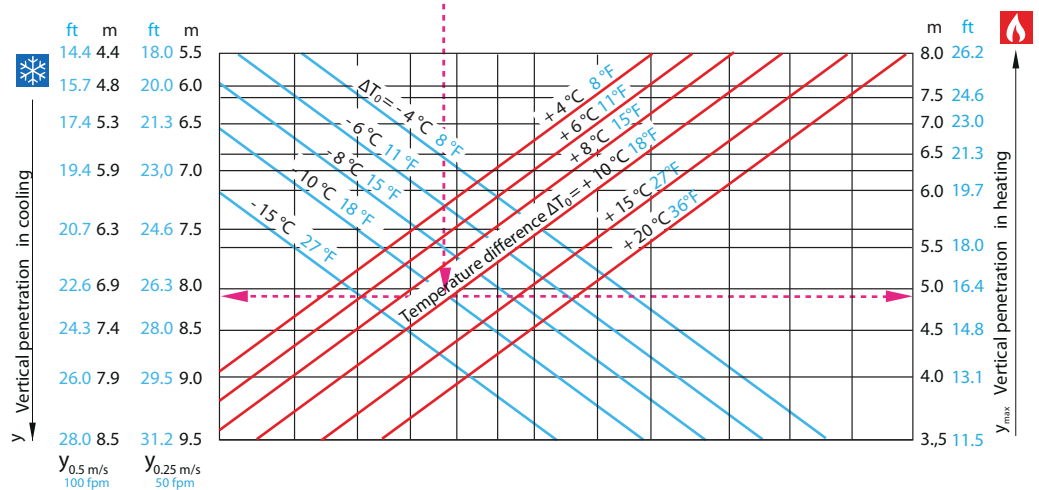
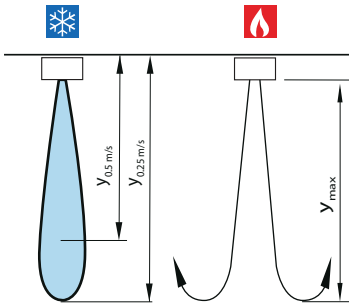
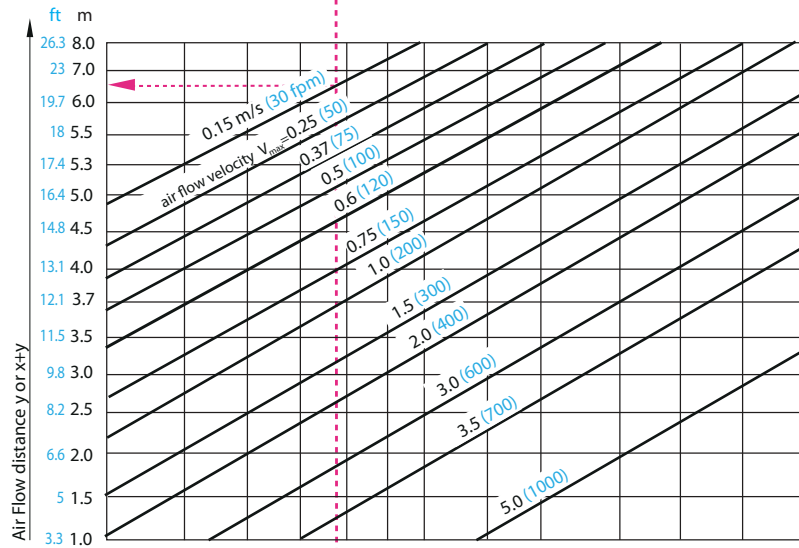
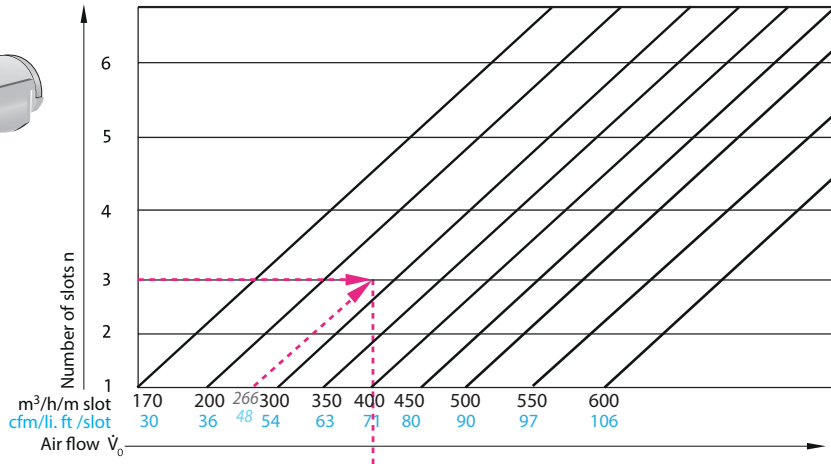
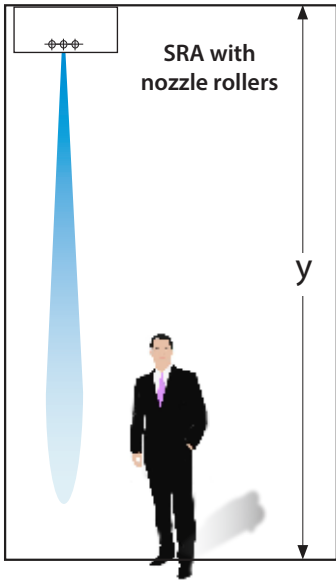
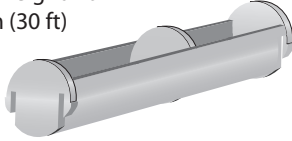

Vertical deflection diagrams

SRA with eccentric rollers

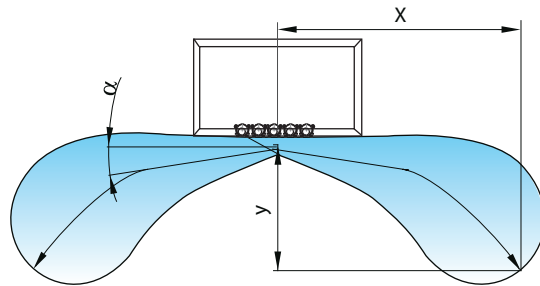
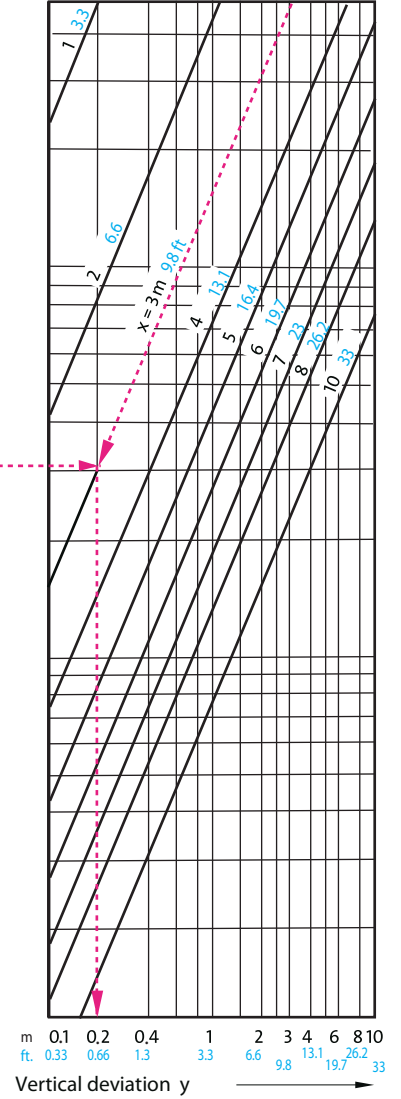
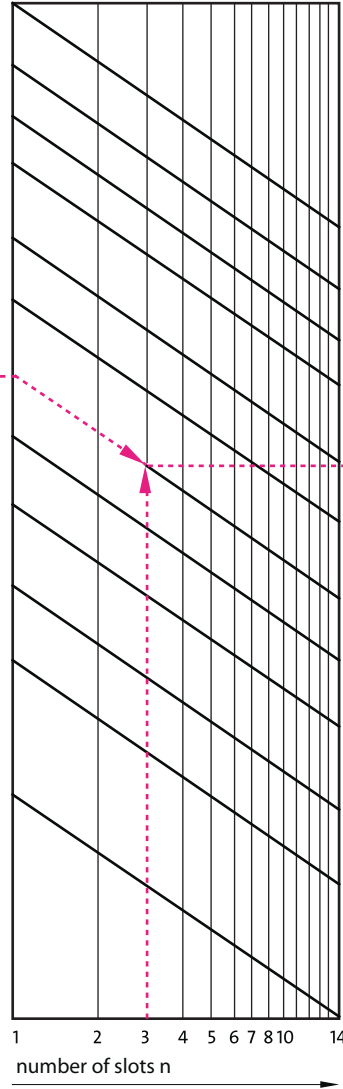
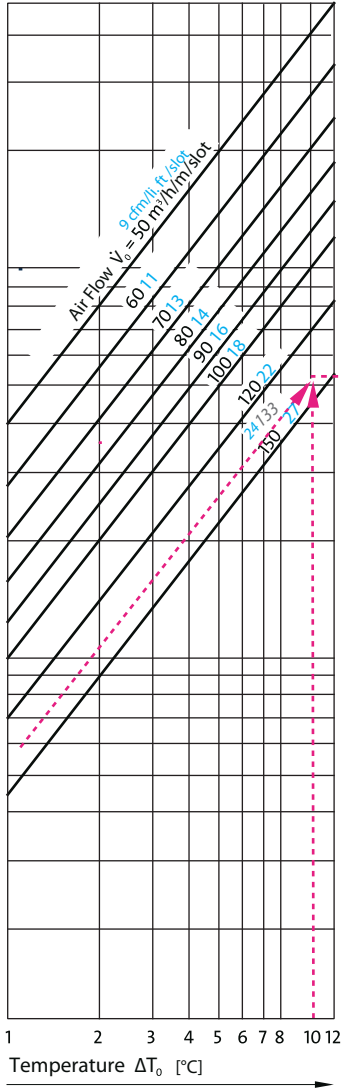

The values of y are valid for the "horizontal jet diffusion" setting. For the setting "horizontal jet divergence", the value is multiplied by a 0.9 factor.

Acoustic power diagrams

SRA with eccentric rollers

NC (with a room absorption of 10 dB)

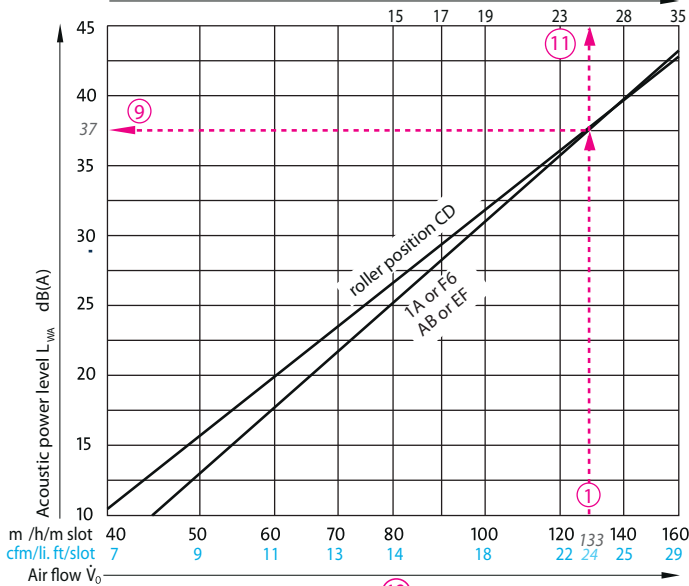

Number of slots	1	2	3	4	5	6	7
NC diagram +	0	3	7	10	13	17	20
Number of slots	8	9	10	11	12	13	14
NC diagram +	24	27	30	33	36	39	42

Number of slots n	$L_{WA} = L_{WA \text{ Diagram}} + \Delta L_{WA}$		
	$L_R = 1000$ $L_S = 800$ ΔL_{WA}	$L_R = 1500$ $L_S = 1300$ ΔL_{WA}	$L_R = 1700$ $L_S = 1500$ ΔL_{WA}
1	0.0	2.1	2.7
2	3.0	5.1	5.7
3	4.7	6.8	7.5
4	6.0	8.1	8.8
5	7.0	9.1	9.7
6	7.8	9.8	10.5
7	8.4	10.5	11.5
8	9.0	11.1	11.8
9	9.5	11.6	12.3
10	10.0	12.1	12.7
11	10.4	12.5	-
12	10.8	12.9	-
13	11.1	13.2	-
14	11.5	13.5	-

L_R = Duct length
 L_S = Slot length

Standard

SRA with nozzle roller

NC (with a room absorption of 10 dB)

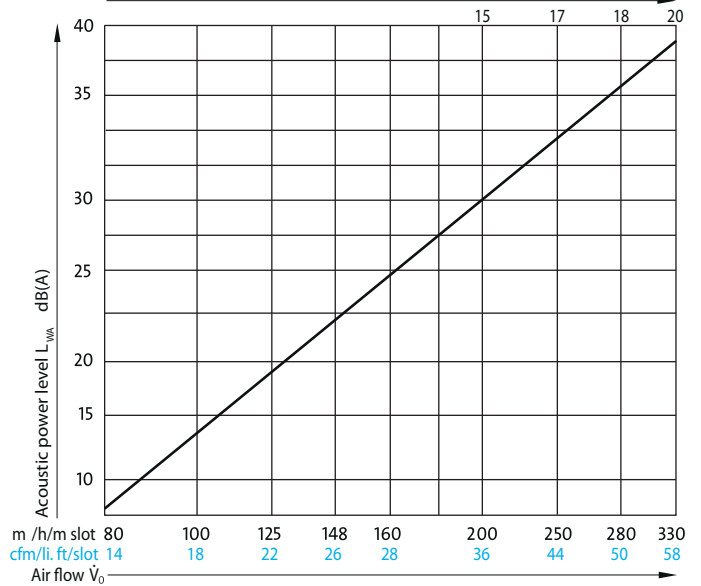

Number of slots	1	2	3	4	5	6	7
NC diagram +	0	5	8	11	15	19	24

Data:

- Total airflow: 2080 m³/h
- Number of SRA sections: 4
- Number of slots per SRA: 3
- Length of the SRA: $L_R = 1450$ mm
- Length of the slot: $L_S = 1300$ mm

Required:

1. Air flow by meter of slot
2. Critical air flow distance X
3. Vertical penetration in heating Y_{max}
4. Acoustic power generated L_{WA} and noise criteria (NC)

Solution:

1. From the total air flow, the number of sections of SRA and the number of slots, we find: $(2080 \text{ m}^3/\text{h} \div 4 \text{ SRA}) \div 3 \text{ slots} = 173 \text{ m}^3/\text{h}$ per slot
For a 1300 mm slot length, we calculate the air flow per meter of slot $173 \text{ m}^3/\text{h} \times 0.77 = 133 \text{ m}^3/\text{h/m}$ slot
2. From the diagram of dimensions, an air velocity in occupied area of 0.25 m/s and a distance after meeting of $y = 3 \text{ m} - 1.8 \text{ m} = 1.2 \text{ m}$, we find a distance of air flow: $X = 3.5 \text{ m}$ (see page 8).
3. For a temperature difference of +10 °C, we find the vertical penetration: $Y_{max} = 2.8 \text{ m}$.
4. From the acoustic power diagram, we read: $L_{WA \text{ diagram}} = 37 \text{ dB(A)}$ and a number of slots $n = 3$: $\Delta L_{WA} = 6.8 \text{ dB(A)}$
Finally, the acoustic power generated is:
 $L_{WA} = L_{WA \text{ diagram}} + \Delta L_{WA} = 43.8 \text{ dB(A)} - 10 \text{ dB(A)} = 33.8 \text{ dB(A)}$
Noise criteria (NC) = 25
With 3 slots, noise criteria (NC : +7) = 32

Dimentional equivalences and weights

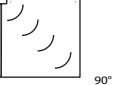



Table of equivalent diameters of rectangular dimensions - to calculate the loss of pressure

Width in mm	6 152	8 203	10 254	12 305	14 356	16 406	18 457	20 508	22 559	24 610	26 660	28 711	30 762	32 813	34 864	36 914	38 965	40 1016	42 1067	44 1118	46 1168	48 1219	
Height in mm	Ø																						
6	152	N/A	6	6	8	8	10	10	N/A	N/A	N/A	N/A	N/A	N/A	N/A	N/A	N/A	N/A	N/A	N/A	N/A	N/A	N/A
8	203	6	8	8	10	10	10	12	12	12	N/A	N/A	N/A	N/A	N/A	N/A	N/A	N/A	N/A	N/A	N/A	N/A	N/A
10	254	6	8	10	10	12	12	12	14	14	14	16	16	16	N/A	N/A	N/A	N/A	N/A	N/A	N/A	N/A	N/A
12	305	8	8	10	12	12	14	14	16	16	16	18	18	18	20	20	20	N/A	N/A	N/A	N/A	N/A	N/A
14	356	8	10	12	12	14	14	16	16	18	18	18	20	20	20	22	22	24	24	24	N/A	N/A	N/A
16	406	8	10	12	14	14	16	16	18	18	20	20	22	22	22	24	24	24	26	26	26	26	28
18	457	10	10	12	14	16	16	18	20	20	20	22	22	24	24	24	26	26	26	28	28	28	30
20	508	N/A	12	14	16	16	18	20	20	22	22	24	24	24	26	26	28	28	28	30	30	30	32
22	559	N/A	12	14	16	18	18	20	22	22	24	24	26	26	28	28	28	30	30	30	32	32	32
24	610	N/A	12	14	16	18	20	20	22	24	24	26	26	28	28	30	30	32	32	32	34	34	34
26	660	N/A	N/A	16	18	18	20	22	24	24	26	26	28	28	30	30	32	32	34	34	34	36	36
28	711	N/A	N/A	16	18	20	22	22	24	26	26	28	28	30	32	32	32	34	34	36	36	38	38
30	762	N/A	N/A	16	18	20	22	24	24	26	28	28	30	32	32	34	34	36	36	36	38	38	40
32	813	N/A	N/A	N/A	18	20	22	24	26	28	28	30	32	32	34	34	36	36	38	38	40	40	40
34	864	N/A	N/A	N/A	20	22	24	24	26	28	30	30	32	34	34	36	36	38	38	40	40	42	42
36	914	N/A	N/A	N/A	20	22	24	26	28	28	30	32	32	34	36	36	38	38	40	40	42	42	44
38	965	N/A	N/A	N/A	N/A	22	24	26	28	30	32	32	34	36	36	38	38	40	40	42	42	44	44
40	1016	N/A	N/A	N/A	N/A	22	24	26	28	30	32	34	34	36	38	38	40	40	42	44	44	46	46
42	1067	N/A	N/A	N/A	N/A	24	26	28	30	30	32	34	36	36	38	40	40	42	44	44	46	46	48
44	1118	N/A	N/A	N/A	N/A	N/A	26	28	30	32	34	34	36	38	40	40	42	42	44	46	46	48	48
46	1168	N/A	N/A	N/A	N/A	N/A	26	28	30	32	34	36	38	38	40	42	42	44	46	46	48	48	50
48	1219	N/A	N/A	N/A	N/A	N/A	28	30	32	32	34	36	38	40	40	42	44	44	46	48	48	50	50

Tableau of weight (indicated for a length of 1450 mm)

Width in mm	6 152	8 203	10 254	12 305	14 356	16 406	18 457	20 508	22 559	24 610	26 660	28 711	30 762	32 813	34 864	36 914	38 965	40 1016	42 1067	44 1118	46 1168	48 1219	
Height in mm	kg																						
6	152	N/A	7,93	9,00	10,07	11,14	12,20	13,27	N/A	N/A	N/A	N/A	N/A	N/A	N/A	N/A	N/A	N/A	N/A	N/A	N/A	N/A	N/A
8	203	7,93	9,00	10,07	11,14	12,20	13,27	14,34	15,40	16,47	17,54	N/A	N/A	N/A	N/A	N/A	N/A	N/A	N/A	N/A	N/A	N/A	N/A
10	254	9,00	10,07	11,14	12,20	13,27	14,34	15,40	16,47	17,54	18,61	23,17	24,43	25,69	N/A	N/A	N/A	N/A	N/A	N/A	N/A	N/A	N/A
12	305	10,07	11,14	12,20	13,27	14,34	15,40	16,47	17,54	18,61	23,17	24,43	25,69	26,94	28,20	29,46	30,71	N/A	N/A	N/A	N/A	N/A	N/A
14	356	11,14	12,20	13,27	14,34	15,40	16,47	17,54	18,61	23,17	24,43	25,69	26,94	28,20	29,46	30,71	31,97	33,23	34,48	35,74	N/A	N/A	N/A
16	406	12,20	13,27	14,34	15,40	16,47	17,54	18,61	23,17	24,43	25,69	26,94	28,20	29,46	30,71	31,97	33,23	34,48	35,74	37,00	38,26	39,51	40,77
18	457	13,27	14,34	15,40	16,47	17,54	18,61	23,17	24,43	25,69	26,94	28,20	29,46	30,71	31,97	33,23	34,48	35,74	37,00	38,26	39,51	40,77	42,03
20	508	N/A	15,40	16,47	17,54	18,61	23,17	24,43	25,69	26,94	28,20	29,46	30,71	31,97	33,23	34,48	35,74	37,00	38,26	39,51	40,77	42,03	43,28
22	559	N/A	16,47	17,54	18,61	23,17	24,43	25,69	26,94	28,20	29,46	30,71	31,97	33,23	34,48	35,74	37,00	38,26	39,51	40,77	42,03	43,28	44,54
24	610	N/A	17,54	18,61	23,17	24,43	25,69	26,94	28,20	29,46	30,71	31,97	33,23	34,48	35,74	37,00	38,26	39,51	40,77	42,03	43,28	44,54	45,80
26	660	N/A	N/A	23,17	24,43	25,69	26,94	28,20	29,46	30,71	31,97	33,23	34,48	35,74	37,00	38,26	39,51	40,77	42,03	43,28	44,54	45,80	47,05
28	711	N/A	N/A	24,43	25,69	26,94	28,20	29,46	30,71	31,97	33,23	34,48	35,74	37,00	38,26	39,51	40,77	42,03	43,28	44,54	45,80	47,05	48,31
30	762	N/A	N/A	25,69	26,94	28,20	29,46	30,71	31,97	33,23	34,48	35,74	37,00	38,26	39,51	40,77	42,03	43,28	44,54	45,80	47,05	48,31	49,57
32	813	N/A	N/A	N/A	28,20	29,46	30,71	31,97	33,23	34,48	35,74	37,00	38,26	39,51	40,77	42,03	43,28	44,54	45,80	47,05	48,31	49,57	50,82
34	864	N/A	N/A	N/A	29,46	30,71	31,97	33,23	34,48	35,74	37,00	38,26	39,51	40,77	42,03	43,28	44,54	45,80	47,05	48,31	49,57	50,82	52,08
36	914	N/A	N/A	N/A	30,71	31,97	33,23	34,48	35,74	37,00	38,26	39,51	40,77	42,03	43,28	44,54	45,80	47,05	48,31	49,57	50,82	52,08	53,34
38	965	N/A	N/A	N/A	N/A	33,23	34,48	35,74	37,00	38,26	39,51	40,77	42,03	43,28	44,54	45,80	47,05	48,31	49,57	50,82	52,08	53,34	54,60
40	1016	N/A	N/A	N/A	N/A	34,48	35,74	37,00	38,26	39,51	40,77	42,03	43,28	44,54	45,80	47,05	48,31	49,57	50,82	52,08	53,34	54,60	55,85
42	1067	N/A	N/A	N/A	N/A	35,74	37,00	38,26	39,51	40,77	42,03	43,28	44,54	45,80	47,05	48,31	49,57	50,82	52,08	53,34	54,60	55,85	57,11
44	1118	N/A	N/A	N/A	N/A	N/A	38,26	39,51	40,77	42,03	43,28	44,54	45,80	47,05	48,31	49,57	50,82	52,08	53,34	54,60	55,85	57,11	58,37
46	1168	N/A	N/A	N/A	N/A	N/A	39,51	40,77	42,03	43,28	44,54	45,80	47,05	48,31	49,57	50,82	52,08	53,34	54,60	55,85	57,11	58,37	59,62
48	1219	N/A	N/A	N/A	N/A	N/A	40,77	42,03	43,28	44,54	45,80	47,05	48,31	49,57	50,82	52,08	53,34	54,60	55,85	57,11	58,37	59,62	60,88

Loss of pressure

ΔP duct		ΔP _L Pressure loss by diameter in elbows $\frac{r}{D} = 1.5$						ΔP _L Reducer		ΔP rollers		
Equivalent diameter* of the duct (see page 12) \varnothing	ΔP Pressure drop by dimension of duct 5 m/s (1000 fpm)									Air flow for slot length of 1 meter		ΔP Loss of pressure over all rollers (1A/F6)
		Pa	inches of water	Pa	inches of water	Pa	inches of water	Pa	inches of water	Eccentric rollers	Nozzle rollers	
in. (mm)	Pa / m (inches of water / 100 ft)	Pa	inches of water	Pa	inches of water	Pa	inches of water	Pa	inches of water	m/hm (cfm/ft)		Pa (Inches of water)
12 (305) ⑦	1.06 (0.13)	14.7	0.05	6.9	0.02	4.2	0.01	0.7	0.003 ⑧	50 (9)	100 (18)	21 (0.08)
14 (356)	0.82 (0.10)	14.7	0.05	6.9	0.02	4.2	0.01			55 (10)	110 (20)	22 (0.09)
16 (406)	0.73 (0.09)	16.5	0.06	7.4	0.03	4.2	0.01			60 (11)	120 (22)	22 (0.09)
18 (457)	0.65 (0.08)	16.5	0.06	7.8	0.03	4.7	0.02			65 (12)	130 (24)	23 (0.09)
20 (508) ⑥	0.57 (0.07)	17.0 ⑨	0.07	7.8	0.03	4.7	0.02			70 (13)	140 (26)	24 (0.09)
22 (559)	0.49 (0.06)	18.0	0.07	8.3	0.04	4.9	0.02			75 (13)	150 (26)	24 (0.10)
24 (610)	0.41 (0.05)	18.0	0.07	8.3	0.04	5.1	0.03			80 (14)	160 (28)	25 (0.10)
26 (660) ⑤	0.41 (0.05)	18.5	0.08	8.3	0.04	5.1	0.03			85 (15)	170 (30)	26 (0.10)
28 (711)	0.37 (0.045)	19.5	0.08	8.6	0.04	5.1	0.03			90 (16)	180 (32)	27 (0.11)
30 (762)	0.37 (0.045)	19.5	0.08	9.5	0.05	5.4	0.03			95 (17)	190 (34)	27 (0.11)
32 (813)	0.33 (0.040)	20.7	0.09	9.5	0.05	5.4	0.03			100 (18)	200 (36)	28 (0.11)
34 (864)	0.29 (0.035)	21.0	0.09	9.8	0.05	5.7	0.04			105 (19)	210 (38)	29 (0.12)
36 (914)	0.29 (0.035)	21.0	0.09	10.5	0.06	5.7	0.04			110 (20)	220 (40)	30 (0.12)
38 (965)	0.24 (0.030)	23.5	0.10	10.5	0.06	6.1	0.04			115 (21)	230 (42)	31 (0.12)
40 (1016)	0.24 (0.030)	23.5	0.10	10.5	0.06	6.1	0.04			120 (22)	240 (44)	33 (0.13)
42 (1067)	0.24 (0.030)	24.0	0.10	11.6	0.07	6.1	0.04			125 (22)	250 (44)	34 (0.14)
44 (1118)	0.20 (0.025)	24.0	0.10	11.6	0.07	6.4	0.05			130 (23)	260 (46)	35 (0.14) ④
46 (1168)	0.20 (0.025)	24.0	0.10	12.0	0.07	6.4	0.05			135 (24)	270 (48)	36 (0.14)
48 (1219)	0.20 (0.025)	24.5	0.10	12.0	0.07	6.5	0.05			140 (25)	280 (50)	38 (0.15)
50 (1267)	0.16 (0.020)	24.5	0.10	12.0	0.07	6.5	0.05			145 (26)	290 (52)	39 (0.16)
52 (1318)	0.16 (0.020)	25.0	0.11	12.5	0.08	6.5	0.05			150 (27)	300 (54)	40 (0.16)
										155 (28)	310 (56)	42 (0.17)
										160 (29)	320 (58)	43 (0.17)
										165 (30)	330 (60)	44 (0.18)
										170 (31)	340 (62)	45 (0.18)

*For the equivalent duct diameter, please refer to the « Table of diameters equivalent of rectangular dimensions », on page 12.

Correction factor for different air velocities in duct:

$$\Delta P = F \times \Delta P \text{ (v = 1000 fpm)}$$

Air velocity in duct	ΔP Pressure drop by diameter in straight duct	ΔP Pressure drop in elbows	ΔP Pressure drop in reducer
m/s (fpm)	F	F	F
3 (600)	0.4	0.5	0.4
4 (800)	0.7	0.7	0.6
5 (1000)	1.0	1.0	1.0
6 (1200)	1.4	1.5	1.4
7 (1400)	1.8	1.8	2.0

Recommended

Correction factor for different adjustments of rollers:

$$\Delta P = F \times \Delta P \text{ (standard adjustment)}$$

Roll adjustment	F
1A / F6	1.0
AB / EF	1.0
CD	1.1
21 / 65	1.1
32 / 54	1.4
CD / 65 - CD / 21	1.1

Example of calculation

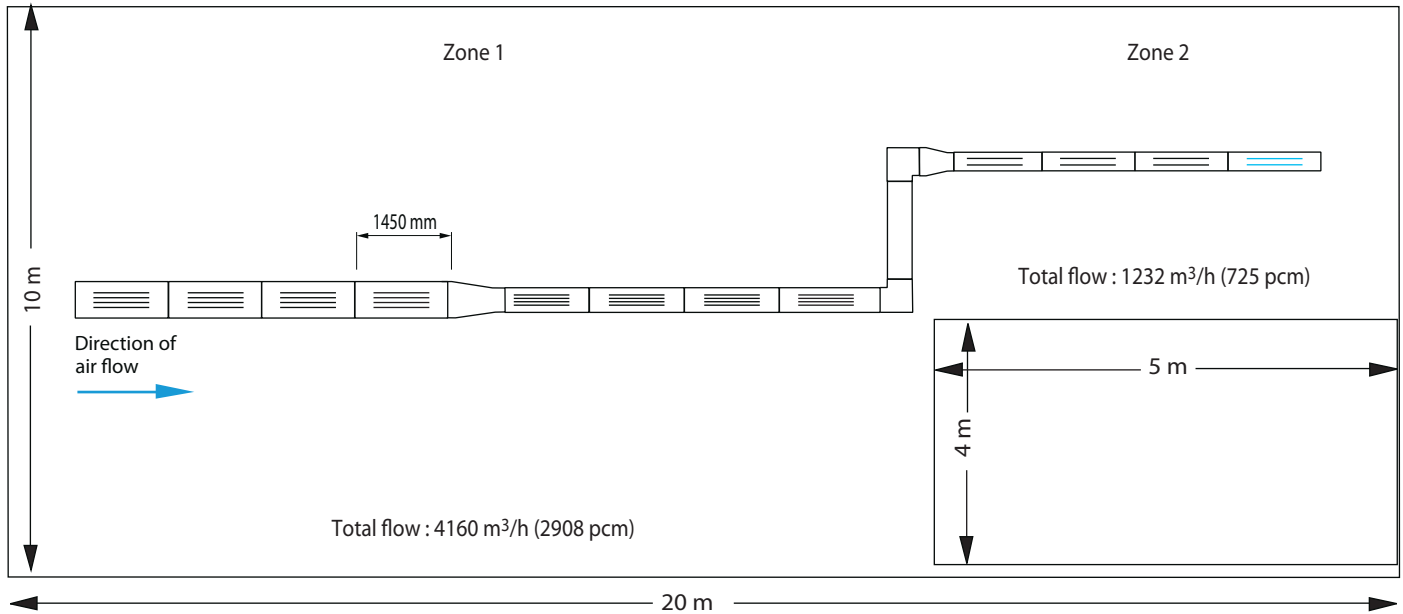

Data:

Air diffusion in two zones
 Air speed in the duct: 5 m/s (1000 fpm)
 Temperature difference: $\Delta T = +10^{\circ}\text{C}$
 Height at the bottom of the duct: 4 m

Zone 1: consists of two (2) sections

Section n° 1:
 - 4 x (active SRA, L = 1500 mm, H x W = 711 x 708 mm)
 - airflow per SRA: 520 m³/h

Section n° 2:

- 1 reducer (657 mm to 505 mm)
 - 4 x active SRA, L = 1500 mm = H x W = 508 x 406 mm
 - 1 x (passive SRA, L = 1500 mm = H x W = 508 x 406 mm)
 - 2 x (90° elbow, H x W = 508 x 406 mm)
 - airflow per SRA: 520 m³/h

Zone 2 : consists of one section

- 1 reducer (505 mm to 302 mm)
 - 4 x (active SRA, L = 1450 mm, H x W = 305 x 254 mm)
 - 1 x (end cap, H x W = 305 x 254 mm)
 - airflow per SRA: 308 m³/h

Questions:

1. What are the total airflows per meter of slot in each zone and the number of corresponding slots?
2. What is the acoustic level L_{WA} ?
3. What are the pressure losses of the installation?

Solutions :

1. The total airflow by meter of slots depends on the airflow diffused by the SRA.

Zone 1: For an airflow per SRA of 520 m³/h and a length of 1500 mm, we calculate the airflow per meter of slots:

$520 \text{ m}^3/\text{h} \times 0.77 = 400 \text{ m}^3/\text{h}/\text{m}$
 From the table "Selecting the number of slots", on page six (6) and for heating mode with a duct height of 4 m, we determine the number of slots: $n = 3$.

Zone 2: the same way, we calculate the airflow per meter of slot sections:
 $308 \text{ m}^3/\text{h} \times 0.77 = 237 \text{ m}^3/\text{h}/\text{m}$
 We determine the number of slots: $n = 2$.

2. From the diagram of acoustic power, the eccentric roller set in positions 21/65 (diffusion) and three (3) slots per SRA:
 $400 \text{ m}^3/\text{h}/\text{m} \div 3 = 133 \text{ m}^3/\text{h}/\text{m}$
 $L_{WA} = L_{WA \text{ Diagram}} + \Delta L_{WA} = 37 + 6.8 - 10 \text{ dB(A)} = 33.8 \text{ dB(A)}$

3. The system's pressure loss is due to the air restriction in the rollers and air friction against the inner walls of the straight ducts, elbows and reducers.

3.1 Loss of pressure at the rollers: from the "Loss of pressure" table and an airflow per meter of slots of 133m³/h/m, we read $\Delta P_{3.1} = 35 \text{ Pa}$ (see page 13) ④

3.2 Pressure loss by duct diameter:

Zone 1, section 1

- The total length of 4 x active SRAs of a dimension H x W = 711 x 708 mm is:
 $L = 4 \times 1450 \text{ mm} = 5.8 \text{ m}$, where:
 $\Delta P_{3.2.1} = 5.8 \text{ m} \times 0.41 \text{ Pa}/\text{m} = 2.4 \text{ Pa}$ ⑤

Zone 1, section 2

- The total length of 4 x active SRAs and 1x passive SRA of dimensions H x W = 508 x 406 mm is:
 $L = 5 \times 1450 \text{ mm} = 7.5 \text{ m}$, where: $\Delta P_{3.2.2} = 7.5 \text{ m} \times 0.57 \text{ Pa}/\text{m} = 4.1 \text{ Pa}$ ⑥

Zone 2

The total length of 4 x active SRAs of a dimensions H x W = 305 x 254 mm is:
 $L = 4 \times 1450 \text{ mm} = 5.8 \text{ m}$, where:
 $\Delta P_{3.2.3} = 6 \text{ m} \times 1.06 \text{ Pa}/\text{m} = 6.1 \text{ Pa}$ ⑦
 - The total loss of pressure in the straight ducts is: $\Delta P_{3.2} = 2.4 + 4.1 + 6.1 = 12.6 \text{ Pa}$

3.3 The loss of pressure in the reducers:
 The equivalent in length of the loss of pressure for two reducers ($\alpha = 14^{\circ}$) is:
 $\Delta P_{3.3} = 2 \times 0.7 \text{ Pa} = 1.4 \text{ Pa}$ ⑧

3.4 The loss of pressure in the elbows:
 The loss of pressure for two (2) 90° elbows with a dimension H x W = 508 x 406 mm is:
 $\Delta P_{3.4} = 2 \times 17 \text{ Pa} = 34 \text{ Pa}$ ⑨

Finally, the system's total pressure loss is:
 $\Delta P_3 = \Delta P_{3.1} + \Delta P_{3.2} + \Delta P_{3.3} + \Delta P_{3.4}$
 so: $\Delta P_3 = 81.7 \text{ Pa}$

Suspension system

Installation with threaded rods

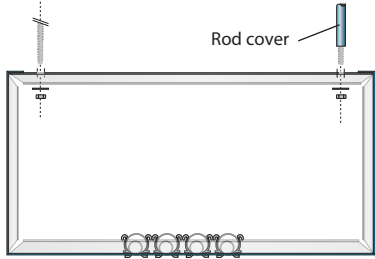

Installation directly to the ceiling

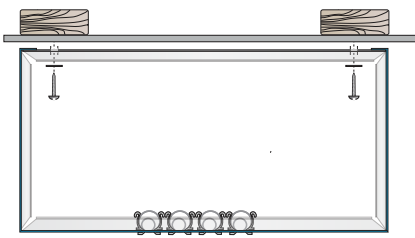

Installation with rail

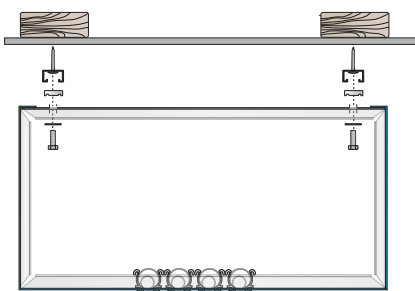

Suspension

The suspension of the SRA diffuser is assured by threaded rods 9.5 mm (3/8") provided by the installer. Upon request, colored rod covers are supplied to cover the threaded rods. It should be noted, however, that the SRA diffusers can be attached directly to the ceiling.

Other methods of suspension are available: the steel suspension rail, which greatly improves installation, or suspension by a high tension metallic cable. These alternative suspension modes can be provided by NAD Klima.

Assembly

The sections of the SRA diffuser are assembled directly one behind the other, without sleeves.

At the extremity, where air exits the duct, a protruding exterior flange acts as a support for the following diffuser which has an interior flange. To unite both diffusers securely together, two screws are provided.

Special attention must be taken regarding the final diffuser, which will have interior flanges on both extremities. The final extremity will receive the cap which completes the section.

A sticker will indicate the direction in which the ducts must be installed.

Dimensioning ducts

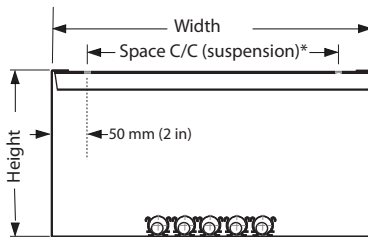

*The space (c/c) between the two holes of suspension is the width of the duct minus 100 mm (4 in).

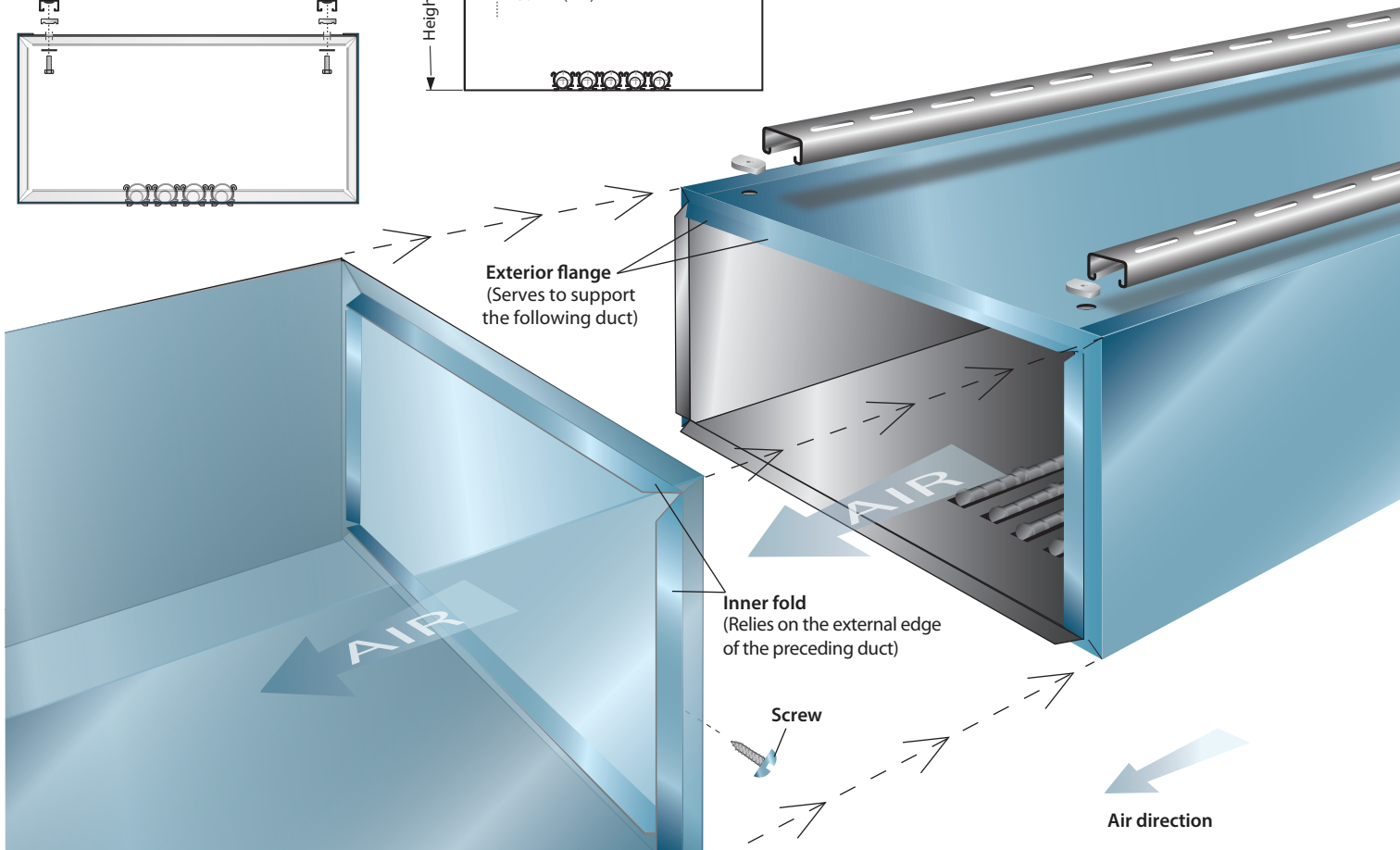

Specifications

1. Description and physical characteristics

- 1.1 The high induction duct diffuser shall be made of 22 ga brushed steel for duct dimensions inferior to 508 mm (20 in) in diameter, and 20 ga for dimensions superior or equal to 508 mm (20 in).
- 1.2 The SRA will be available in dimensions ranging from 152 mm (6 in) to 1219 mm (48 in) for width and height, and up to 1450 mm (57 in) for length.
- 1.3 The duct diffuser shall be painted with a TGIC-free polyester powder coat. It shall have a smooth surface for easy cleaning. The colour shall be chosen by the architect or the customer. The diffuser paint shall be guaranteed against peeling for a minimum period of 5 years when used under normal conditions.
- 1.4 The duct diffuser shall be supplied with slots containing ABS (black or white) eccentric rollers or nozzle rollers. The 100 mm long eccentric rollers shall be alphanumerically identified, allowing for an adjustment of the air flow pattern over 180 degrees. The nozzle rollers will be opened or closed.
- 1.5 The duct shall have an as smooth as possible surface, without sleeves to maintain an esthetic appeal.
- 1.6 A reducer fitting or a perforated balancing damper with a self locking mechanism, allowing for an output between 25% and 100%, shall be installed after a maximum of 5 consecutive active sections of the same dimensions. A slot register shall be integrated to the last active section of the system.
- 1.7 The duct diffuser can be passive, without slots.

2. Installation and suspension

- 2.1 The SRA duct can be screwed directly to the ceiling in the holes designed for this purpose. The suspension screws will be supplied by the installer.
- 2.2 When required, the duct diffuser's suspension shall be available in three options.
 - 2.2.1 Rail suspension**
The duct diffuser shall be slid into a suspended steel rail, offering a solution for varied types of ceilings. The rail shall be painted according to the RAL colour chart and chosen by the architect or customer.

2.2.2 Suspension by metallic cable

The duct diffuser shall be suspended by a metallic cable (aviation style) (7 X 7 or 7 X 9), of galvanised or stainless steel (304 or 316), of medium or high traction resistance.

2.2.3 Suspension by threaded rods 9.5 mm (3/8 in) provided by the installer. The threaded rods can be covered with rod covers supplied by the manufacturer of the diffuser. The color of the rod cover according to RAL color chart, will be the choice of the architect or the customer.

- 2.3 When the duct diffuser goes through a wall, a collar adapted to the duct diffuser shall be supplied by the manufacturer.
- 2.4 The standard accessories shall have the same finish as the duct diffuser (elbows, sleeves, reducers, branches, etc.).
- 2.5 Each diffuser shall be identified with a label. This label shall contain the section number, direction of the air flow, number of slots and positioning of the eccentric rollers.

3. Performances

The manufacturer shall demonstrate for approval, the performance curves indicating air velocity, pressure loss and sound power level generated by the diffuser.

4. Adjustment

- 4.1 Adjusting the eccentric rollers shall be done by the manufacturer according to the required output.
- 4.2 The adjustment of the eccentric rollers shall be possible even after the installation of the diffuser, in order to meet new output requirements.

5. Balancing

- 5.1 Balancing the diffusers shall be done by a ventilation balancing technician, accredited as a qualified professional.
- 5.2 When required, the technician shall refer to the eccentric roller adjustment mode available in the manufacturers' reference manual.

6. Required quality: NAD Klima model SRA

Codification

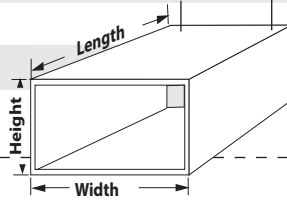
SRA		Product
1000 (800), 1450 (1300)		Length (L_R)
0800, 0900, 1000, 1100, 1200, 1300		Length of the slots (L_S)
152*, 203, 254, 305, 356, 406, 457, 508, 559, 610, 660, 711, 762, 813, 864, 914, 965, 1016, 1067, 1118, 1168, 1219		Width (Horizontal measures)
152*, 203, 254, 305, 356, 406, 457, 508, 559, 610, 660, 711, 762, 813, 864, 914, 965, 1016, 1067, 1118, 1168, 1219		Height (Vertical measures)
XX, 01, 02, 03, 04, 05, 06, 07, 08, 09, 10, 11, 12, 13, 14		Number of slots
003 = Slots at 3h 006 = Slots at 6h 009 = Slots at 9h 036 = Slots at 3h and at 6h 039 = Slots at 3h and at 9h 069 = Slots at 6h and at 9h 369 = Slots at 3h, at 6h and at 9h XXX = Passive		Slot position
XXX = Passive DFS = Diffuse standard 21/ 65 DFR = Diffuse window DE / 21 DFL = Diffuse window BC / 65 DFF = Diffuse height AB / EF DFT = Diffuse CD / EF - slots at 3 h DFN = Diffuses CD / AB - slots at 9 h DFH = Diffuse height BC / DE DFA = Diffuse AB / DE DVB = Divergent 21 DVD = Divergent 65 DVV = Vertical divergent CD DRB = Divergent with nozzle rollers		Air flow
W = White eccentric roller or nozzle roller (RAL 9003) C = Cream eccentric roller (RAL 9010) B = Black eccentric roller or nozzle roller X = Without roller		Roller color
9003 = White 9010 = Cream 00SB = Solar Black (Standard matte black) 00SM = Silver Matte (Standard metallic grey) _____ = RAL color (write the color number)		Diffuser color
A = With closed-cell acoustic insulation X = Without insulation		Acoustic insulation
D = With damper X = Without damper		Damper
R = With register (perforated plate) X = Without register		Register
SRA - 1450 - 1300 - 203 X 254 - 03 - 006 - DFS - W - 9003 - X - X	Annotation	Example

* Ducts with dimensions 152 X 152 are not available

Codification for end caps, collars, bivelled end caps

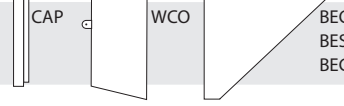
SRA	CAP = End cap WCO = Collar BEC = Bivelled end cap, BES = with slots (return), BEG = with grid (return)		Product
152, 203, 254, 305, 356, 406, 457, 508, 559, 610, 660, 711, 762, 813, 864, 914, 965, 1016, 1067, 1118, 1168, 1219			Width (Horizontal measures)
152, 203, 254, 305, 356, 406, 457, 508, 559, 610, 660, 711, 762, 813, 864, 914, 965, 1016, 1067, 1118, 1168, 1219			Height (Vertical measures)
9003 = White 9010 = Cream 00SB = Solar Black (Standard matte black) 00SM = Silver Matte (Standard metallic grey) _____ = RAL color (write the color number)			Diffuser color
A = With closed-cell acoustic insulation X = Without insulation			Acoustic insulation
SRA - CAP - 203 X 254 - 9003 - X			Example

Standard

Codification of accessories

Elbows codification

SRA	ELB = Elbow		Product
	15, 30, 45, 60, QA	15° 30° 45° 60° QA	Angle
	152, 203, 254, 305, 356, 406, 457, 508, 559, 610, 660, 711, 762, 813, 864, 914, 965, 1016, 1067, 1118, 1168, 1219		Width (Horizontal measures)
	152, 203, 254, 305, 356, 406, 457, 508, 559, 610, 660, 711, 762, 813, 864, 914, 965, 1016, 1067, 1118, 1168, 1219		Height (Vertical measures)
	9003 = White 9010 = Cream 00SB = Solar Black (Standard matte black) 00SM = Silver Matte (Standard metallic grey) ____ = RAL color (write the color number)		Color
	A = With closed-cell acoustic insulation X = Without insulation		Acoustic insulation
SRA	ELB - 15 - 203 X 203 - 9003 - X		Example

Reducers codification

SRA	RED = Reducer		Product
	T = Eccentric - top (standard) C = Center B = Eccentric - bottom	T C B	Configuration
	203, 254, 305, 356, 406, 457, 508, 559, 610, 660, 711, 762, 813, 864, 914, 965, 1016, 1067, 1118, 1168, 1219		Inlet Width
	152, 203, 254, 305, 356, 406, 457, 508, 559, 610, 660, 711, 762, 813, 864, 914, 965, 1016, 1067, 1118, 1168, 1219		Inlet Height
	152, 203, 254, 305, 356, 406, 457, 508, 559, 610, 660, 711, 762, 813, 864, 914, 965, 1016, 1067, 1118, 1168, 1219		Outlet Width
	152, 203, 254, 305, 356, 406, 457, 508, 559, 610, 660, 711, 762, 813, 864, 914, 965, 1016, 1067, 1118, 1168, 1219		Outlet Height
	S = Standard $\alpha = 14^\circ$ A = Other (specify in annotation)		Length
	9003 = White 9010 = Cream 00SB = Solar Black (Standard matte black) 00SM = Silver Matte (Standard metallic grey) ____ = RAL color (write the color number)		Color
	A = With closed-cell acoustic insulation X = Without insulation		Acoustic insulation
SRA	RED - T - 203 X 203 - 203 X 203 - S - 9003 - X		Example

Blue : Standard

Branch codification

SRA	BRA = branch		Product
	152, 203, 254, 305, 356, 406, 457, 508, 559, 610, 660, 711, 762, 813, 864, 914, 965, 1016, 1067, 1118, 1168, 1219		Inlet Width
	152, 203, 254, 305, 356, 406, 457, 508, 559, 610, 660, 711, 762, 813, 864, 914, 965, 1016, 1067, 1118, 1168, 1219		Inlet Height
	152, 203, 254, 305, 356, 406, 457, 508, 559, 610, 660, 711, 762, 813, 864, 914, 965, 1016, 1067, 1118, 1168, 1219		Outlet Width
	152, 203, 254, 305, 356, 406, 457, 508, 559, 610, 660, 711, 762, 813, 864, 914, 965, 1016, 1067, 1118, 1168, 1219		Outlet Height
	T, S, W	T S* W*	Configuration
	9003 = White 9010 = Cream 00SB = Solar Black (Standard matte black) 00SM = Silver Matte (Standard metallic grey) ____ = RAL color (write the color number)		Color
	A = With closed-cell acoustic insulation X = Without insulation		Acoustic insulation
SRA	BRA - 305 X 305 - 203 X 203 - T - 9003 - X		Example

Notes: The « W » branch may have two different outlet diameters. * For « S » and « W » fittings, add an elbow to the degree and diameter chosen to complete the branch.

Codification of the suspension accessories

Coding for anchorage system, with rail

RAI	S-33 Steel rail 22 mm X 41 mm X 3048 mm (7/8 in X 1 5/8 in X 10 li. ft) can be paint	<i>A: 50 mm (2 in)</i> <i>B: 22 mm (7/8 in)</i>	
	9003 = White 9010 = Cream ____ = RAL color (4 number) XXXX = No paint	Color	
RAI	S33 - 9003	Example	
Accessories supplied with the steel rail (S33) (2/SRA)			
RKS	Fastening system Bolt, washer, lock washer and nut		

Coding for suspension accessories with threaded rods
(threaded rods are supplied by the installer)

RCT	Threaded rod cover 16 mm x 3.05 m (5/8 in x 10 ft)	
	9003 = White 9010 = Cream 00SB = Solar Black 00SM = Silver Matte ____ = RAL color (4 numbers) XXXX = No paint	Color
RCT	- 9003	Example
Touch-up spray paint		
CAN	9003 Paint can (RAL 9003)	
CAN	____ Paint can (other RAL color - 4 number)	
CAN	- 9003	Example

Anchorage with cable

Description of anchors for the ceiling	
CPA	Anchor with hook nickel plated Ø 13 mm X 70 mm X 14.3 mm (Ø 1/2 in X 2 3/4 in X 9/16 in)
CCP	Swiveling anchor nickel plated Not adjustable Ø 25 mm X 28.5 mm (Ø 1 in X 1 1/8 in) (screw not supplied)
Description of anchor for the diffuser	
CCA	Anchor for duct Adjustment throttle nickel plated Ø 19 mm X 50 mm (Ø 3/4 in X 2 in)
	XXXX = Without cable 3048 mm - standard (10 ft)
	Cable length
	A = Nickel plated steel (standard) S = Stainless Steel (optional)
CPA	- 3048 - A
	Example

nad
K L I M A

www.nadklima.com

NAD Klima

144, rue Léger,

Sherbrooke, QC, J1L 1L9 Canada

T : 819 780-0111 • 1 866 531-1739

info@nadklima.com

MADE IN

CANADA