

nad  
KLIMA

MADE IN  
CANADA

# SAL35

Linear diffuser  
catalog 1.1.3







TPSGC, Québec, Canada



## SAL 35

---

### Table of content

Description, areas of application and benefits . . . . .	1
Configuration and mode of operation . . . . .	2
Direction of the air flow . . . . .	3
Selection of the number of slots	
- Diffuser with eccentric rollers . . . . .	4
- Diffuser with nozzle rollers . . . . .	5
Diagrams of air flow velocity and loss of pressure	
- Diffuser with eccentric rollers . . . . .	6
- Diffuser with nozzle rollers . . . . .	7
-Acoustic power level . . . . .	8
Dimensions	
- Dimensions of profile and installation . . . . .	10
- Dimensions of diffuser with plenum . . . . .	11
- Total length with end cap . . . . .	14
End cap and connectors. . . . .	15
Specifications. . . . .	16
Codification . . . . .	17

---





University of Québec, Rimouski, Canada

## Presentation and benefits

The SAL 35 diffuser is composed of extruded aluminum surfaces with eccentric rollers, which slide inside and are mounted on the plenum, as well as linear slots with 35 mm profiles. Each diffuser is supplied with a stabilising chamber, allowing for a uniform and silent airflow.

The SAL 35 is available with one or multiple slots, depending on the application and required amount of air. The diffusers can be installed in series, one behind the other, creating a continuous effect to the ceiling.

The SAL enables optimal configuration of the ventilation system to meet a room's requirements. Due to the eccentric rollers, a variety of airstream configurations can be achieved, even after the unit has been installed.

The SAL 35's technology provides high speed discharge of air with low acoustic power.

The laminar flow, the stability and the high induction generated from the very start of the outlet vent make the SAL the linear diffuser of choice for high air flow rates and variable air volumes.



### Benefits

- Influence on the method of induction (diffuse mode), extension of jets (divergent mode) and a very long vertical stream in heating mode (divergent nozzle rollers)
- Rapid reduction of flow speed and temperature variations caused by high induction
- Low acoustic power for high airflow rates
- Stable laminar airflow and a variety of airflow directions available
- Eccentric rollers allowing 180° airflow adjustment
- Possibility of adjusting airflows, even after installation
- Possibility of reducing total airflow rate as much as 25% in VAV
- Approximately 3 times more induction than a conventional linear diffuser
- Approximately 3 times less temperature variation in occupied area than a traditional diffuser
- Possibility of eliminating external heating sources due to the diffuser's heating abilities
- Adaptable to systems requiring constant or variable airflows
- Areas with high air movement and low air velocity in the occupied zone

### Areas of application

- Rooms with average ceiling heights
- Situations where the diffuser must adapt to the contours and colours of the room
- Offices with partitioned workspaces
- Clean rooms
- Call centres
- Closed offices
- Computer (server) rooms
- Meeting rooms
- Multi-purpose rooms
- Systems with constant or variable airflow rates
- Entrance halls (vertical air streams)
- Fenestrated walls
- Theaters



## Configuration and mode of operation

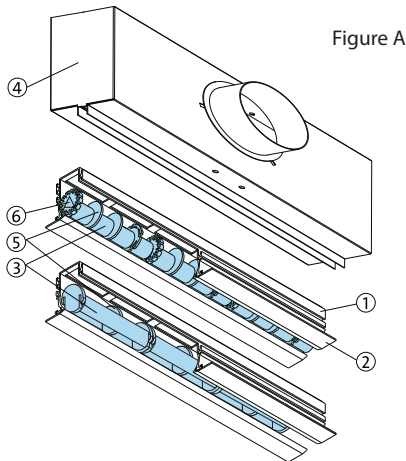

- ① Extruded aluminum profile
- ② Wide or narrow finishing profile
- ③ Eccentric rollers
- ④ Plenum
- ⑤ Air guiding blades
- ⑥ Display and adjustment dial.

### Configuration

The SAL linear diffuser slots are composed of extruded aluminum (1) with additional wide or narrow finishing profiles (2), eccentric rollers (3), which can rotate on 360 degrees and a plenum (4).

The 100 mm long eccentric rollers (3) offer a low acoustic level and optimal aerodynamics. They possess on their axis multiple air guiding planes (5), a display and adjustment dial (6) on which are alphanumeric characters, allowing the user to define and reproduce the roller settings.

The nozzle roller is the same dimension as the eccentric roller, with a larger effective surface. It is designed for application in locations with high ceilings.

The profiles are attached to the plenum with screws for suspended ceilings and with central screws for gypsum ceilings.

The diffuser is powder coated with a polyester TGIC-free paint, providing a smooth, easy-to-clean, chip and fade resistant finish. The colours are available from the RAL colour chart.

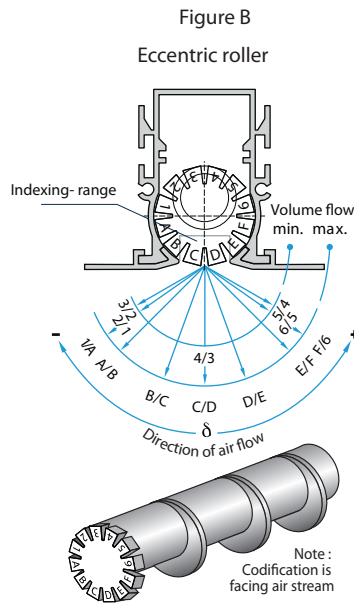

### Mode of operation

The eccentric rollers and nozzle rollers form, combined with aluminum air guiding slots, an optimal air flow.

A drop in pressure occurs when approaching the surface of the rollers. As the air leaves the slot, it is stable and generates a low level of acoustic power. The flow maintains a powerful induction of ambient air.

The positioning of the eccentric rollers allows an adjustment of the air jet's direction, with or without reduction in the exit area.

Rollers have small plates to guide the air, which support a dense airflow and maintain the air flow direction perpendicular to the rollers' axis.

### Operation

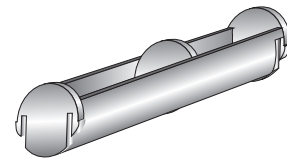
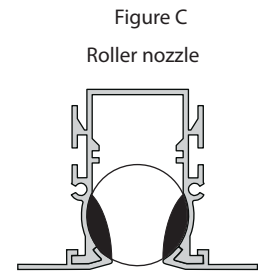
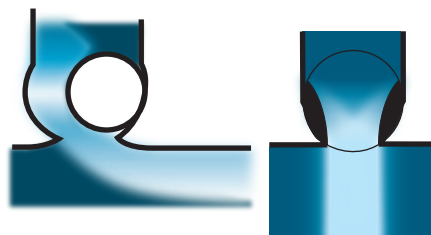

### Adjustment of the air jet direction

Thanks to the shape of eccentric rollers and adjustment dial with alphanumeric characters, the direction of the air jet at the diffuser's outlet can vary up to 180°. For each direction, there are two (2) roller positions ("reduced" or "not reduced"), as illustrated in figure B.

For a ceiling installation, a horizontal airflow is generated by the Coanda effect, with the rollers in positions EF, F6, 1A, AB and 21, 32, 54 and 65. The length of the rollers is adjustable up to 100 mm.

As a result, the combinations of airflow are almost infinite. During manufacturing, rollers are normally set alternately in position 21 and 65 (diffusion mode). This setting produces a strong induction flow, which is effective even in high cooling needs and mixed air rates.

The nozzle roller can only be set in open and closed positions.

## Direction of air flow

### Air jet on one side

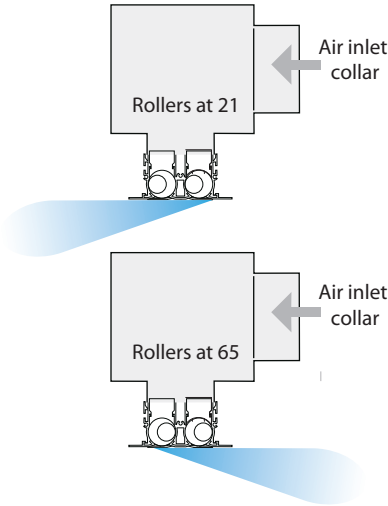

### Controlling the direction of airflow

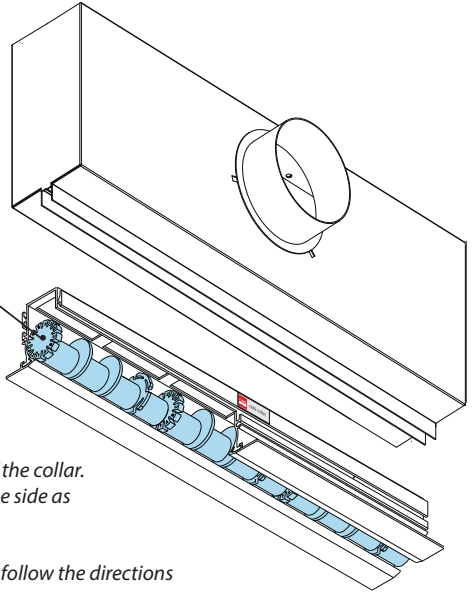
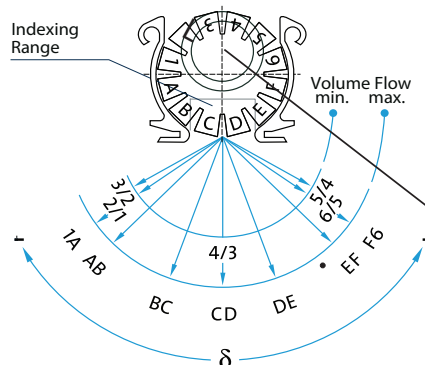

**Notes :**  
 The adjustable side of the roller must be to the left of the collar.  
 During assembly, the NAD label is placed on the same side as the collar of the plenum.

When the air inlet is on the top or a wall installation, follow the directions on the workshop design.

### Examples of application

The diagrams below illustrate the different relationships between the position of the eccentric rollers and the air jet's direction at the roller's outlet.

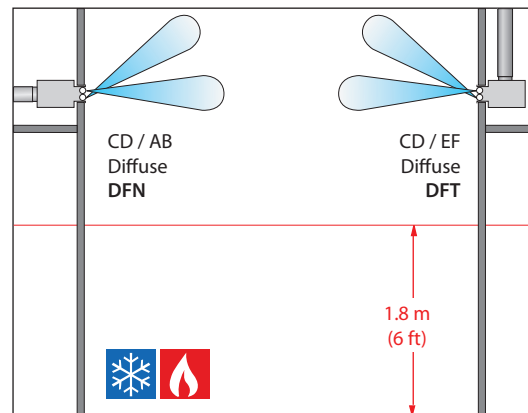
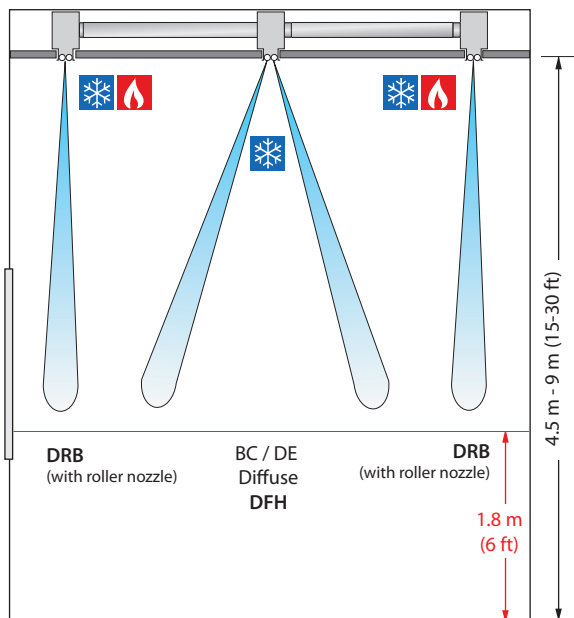
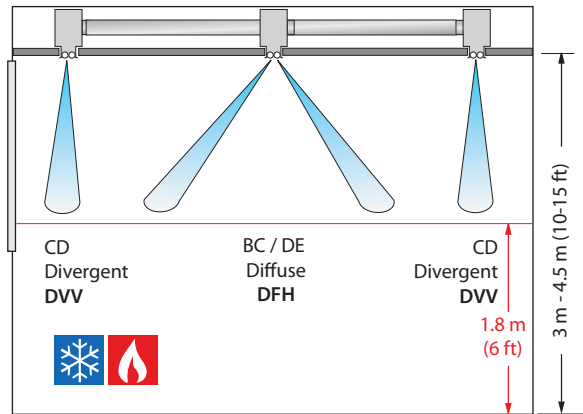
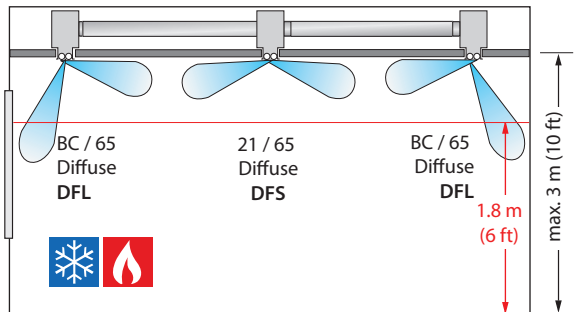

## Selection of number of slot with eccentric rollers

For an installation height up to 4.3 m (14 ft)

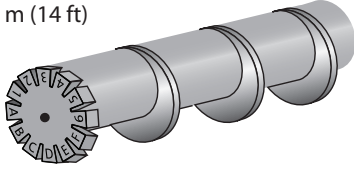

**Note:**

To facilitate the selection of the SAL, total airflow must be calculated for active slot lengths of 1 m.

**Specifications:**

Height of the air-duct:  $H = 2.74 \text{ m (9 ft)}$   
 Airflow by diffuser:  $\dot{V}_0 = 384 \text{ m}^3/\text{h}$   
 Cooling:  $\Delta T = -15^\circ\text{C}$   
 Heating:  $\Delta T = +15^\circ\text{C}$   
 Length of SAL:  $L = 1500 \text{ mm}$

**Required:**

- 1- Airflow by meter of slot section
- 2- Number of slots  $n$  in cooling

**Solution:**

Each slot of 1500 mm = 1.5 m of length, which we divide by 1.5 to find the air flow by meter of slot:  $324 \text{ m}^3/\text{h} / 1.5 = 256 \text{ m}^3/\text{h/m}$  ①

From the diagram "Number of slots" and in a cooling mode, we find the number of slots:  $n = 3$ . ②

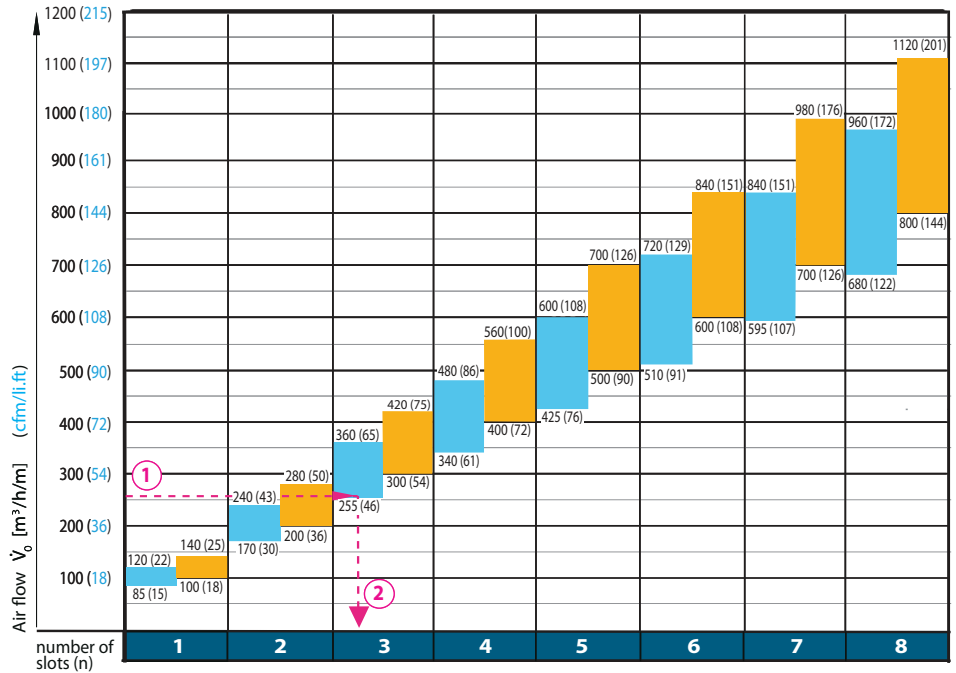

	Air Flow by meter of slot of SAL 35 $\dot{V}_0$	$\text{m}^3/\text{h/m} / \text{slot}$ ( $\text{cfm} / \text{li.ft} / \text{slot}$ )
<span style="color: #00AEEF;">■</span> Cooling only for all ceiling heights		85 - 120 (15 - 22)
<span style="color: #00AEEF;">■</span> Heating and cooling for ceiling heights $\leq 3.0 \text{ m (10 ft)}$		85 - 120 (15 - 22)
<span style="color: #FFC000;">■</span> Heating and cooling or heating only for heights of 3.0 m (10 ft) - 4.3 m (14 ft)		100 - 140 (18 - 25)

- In the case where heating mode can not be selected with initial air flow, reduce the length  $L_s$  of the slot in accordance with the air flow per meter of slot recommended.
- In critical acoustic environment, increase the number of slots.



Congress Center, Drummondville, Canada



## Selection of number of slots with roller nozzle

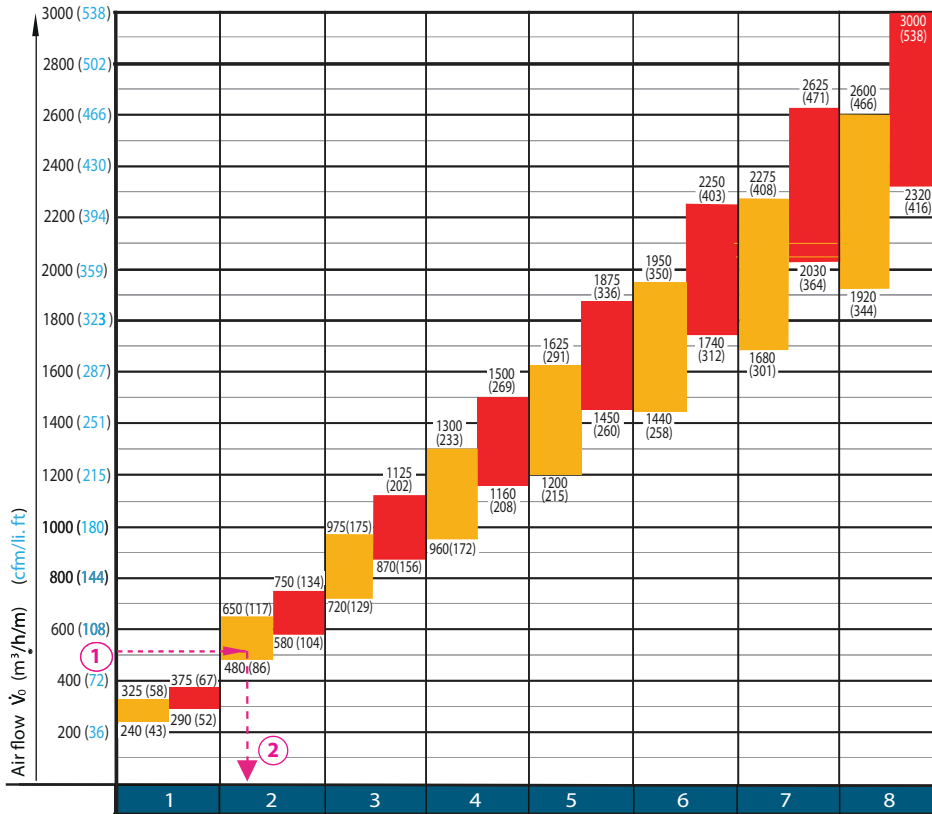

For an installation height from 4.3 m (14 ft) to 9 m (30 ft)

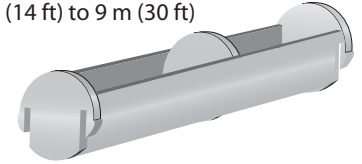

**Note:**  
To facilitate the selection of the SAL 35, total airflow must be calculated for active slot lengths of 1 m.

**Specifications:**

Height of the air-duct:  $H = 5.00 \text{ m}$   
 Airflow by diffuser:  $\dot{V}_0 = 770 \text{ m}^3/\text{h}$   
 Cooling:  $\Delta T = -15^\circ\text{C}$   
 Heating:  $\Delta T = +15^\circ\text{C}$   
 Length of SAL:  $L = 1500 \text{ mm}$

**Required:**

- 1- Airflow by meter of slot section
- 2- Number of slots (n) in cooling

**Solution:**

① Each slot of 1500 mm = 1.5 m of length, which we divide by 1.5 to find the air flow by meter of slot:  $770 \text{ m}^3/\text{h} / 1.5 = 513 \text{ m}^3/\text{h/m}$

② From the diagram "Number of slots" and in a cooling mode, we find the number of slots:  $n = 2$ .

Air Flow by meter of slot of the SAL 35 $\dot{V}_0$	$\text{m}^3/\text{h}/\text{m}/\text{slot}$ (cfm/li.ft/slot)
Heating only for ceiling heights of 4.3 m (14 ft) - 6.1 m (20 ft)	240 - 325 (42 - 57)
Heating only for ceiling heights of 6.1 m (20 ft) - 9 m (30 ft)	290 - 375 (51 - 66)

- In the case where heating mode can not be selected with initial air flow, reduce the length  $L_s$  of the slot in accordance with the air flow per meter of slot recommended.
- In critical acoustic environment, increase the number of slots.



## Diagrams of air flow velocity and loss of pressure with eccentric rollers

For an installation height up to 4.3 m (14 ft)

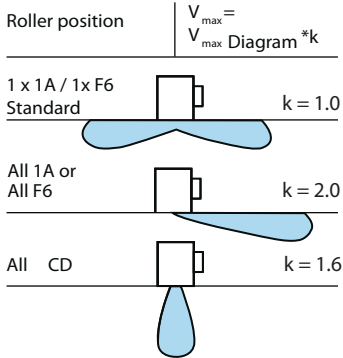
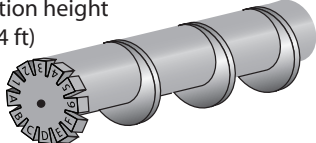

Airflow distance after meeting y

6.6	4.9	3.3	1.6	0 m
2	1,5	1	0,5	ft

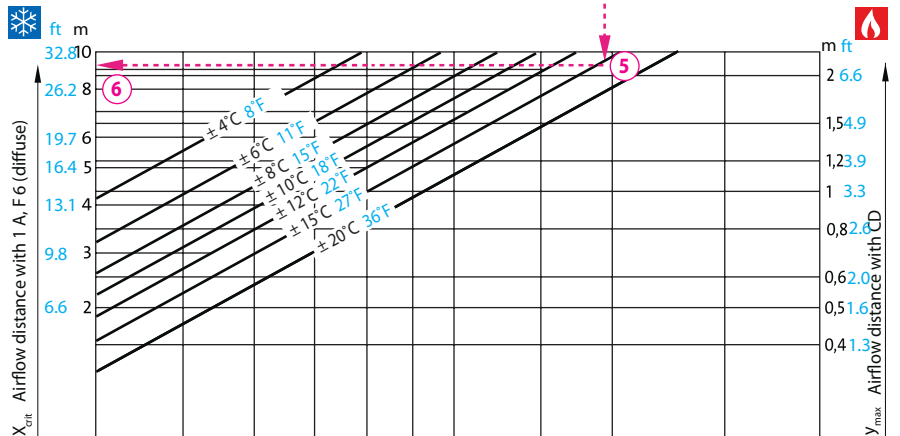
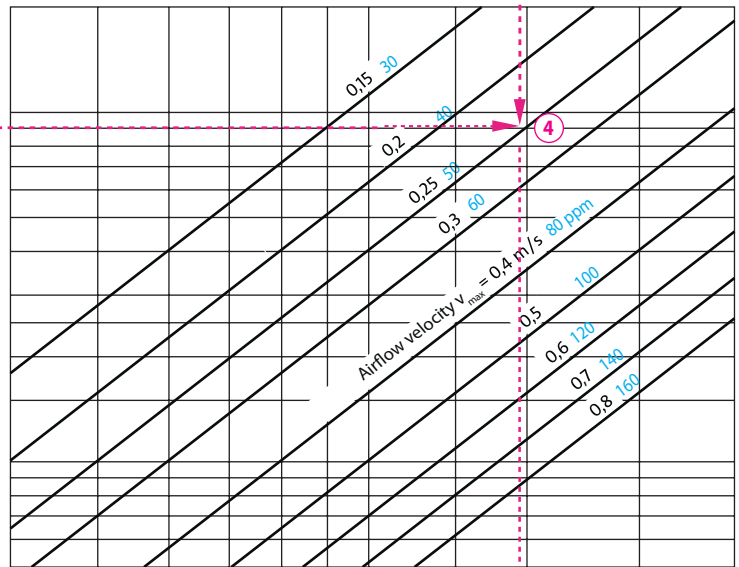
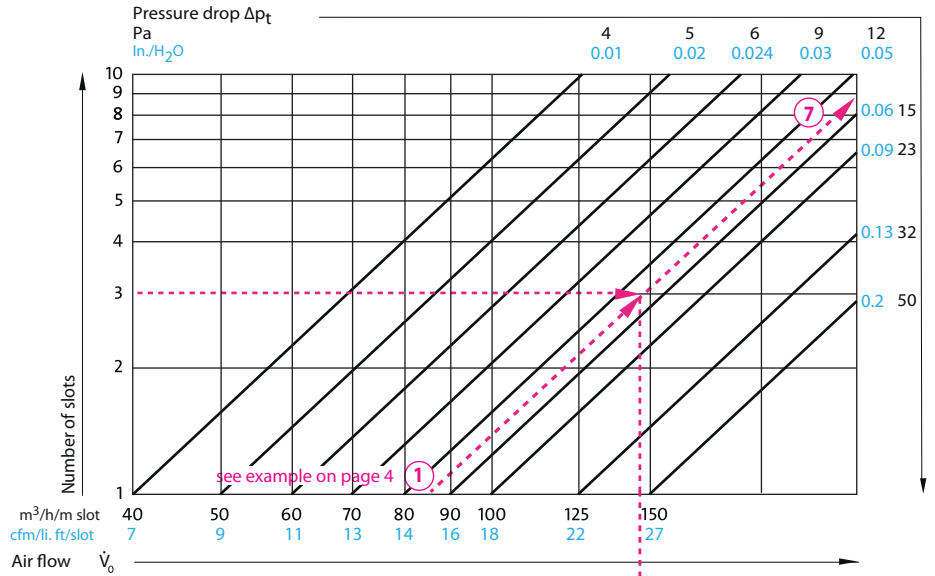
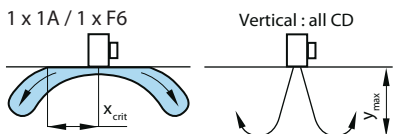
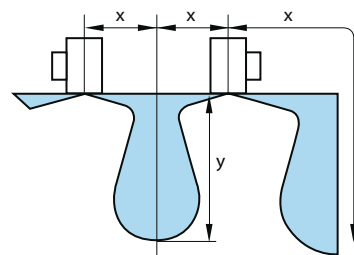
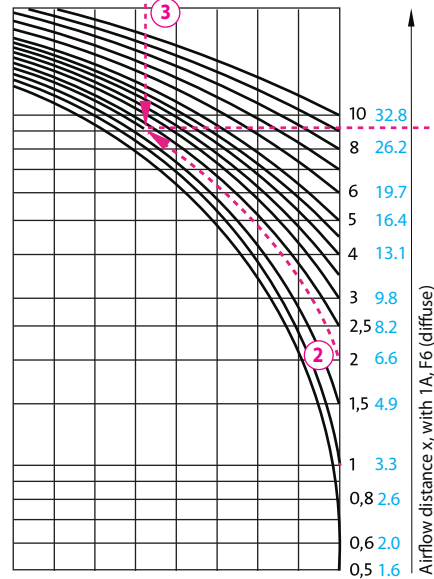



## Diagrams of air flow velocity and loss of pressure with rollers nozzle

For an installation height from 4.3 m (14 ft) to 9 m (30 ft)

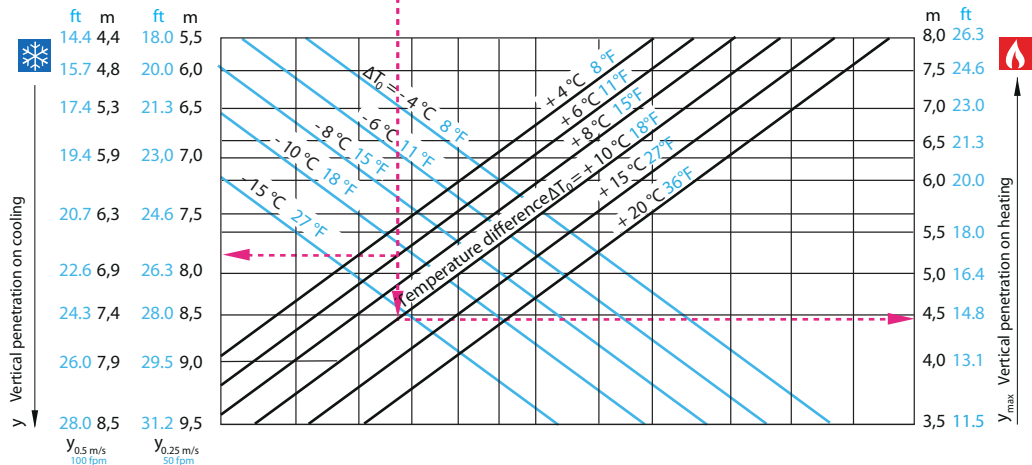
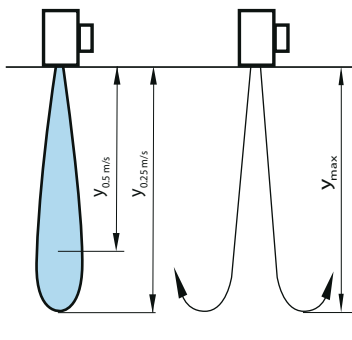
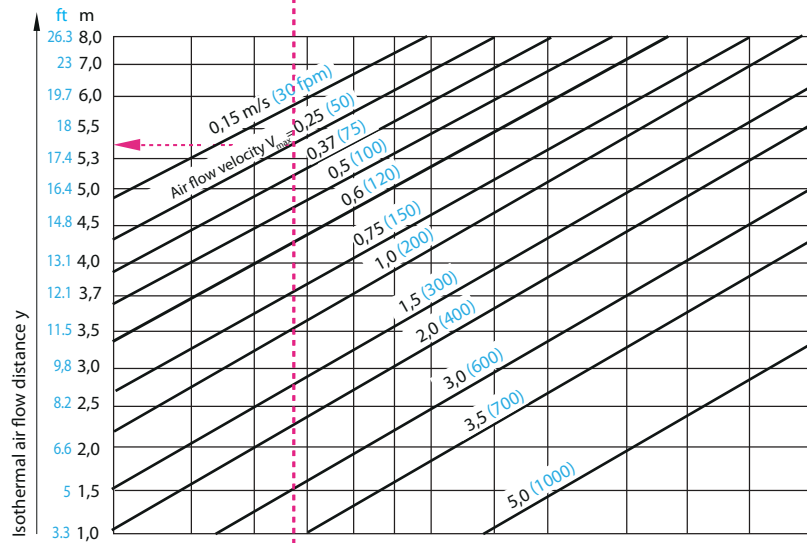
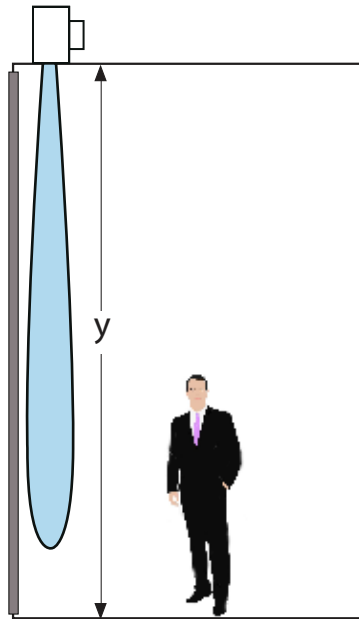
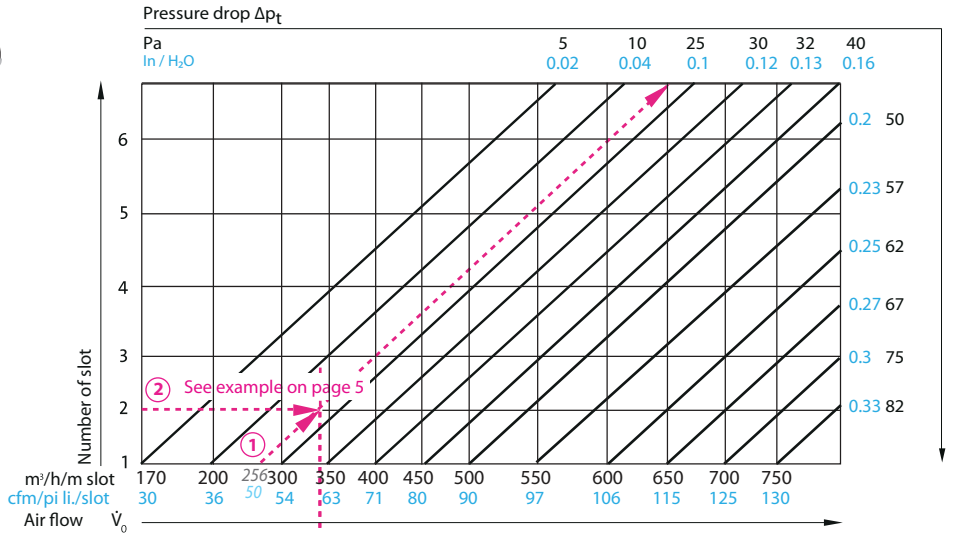
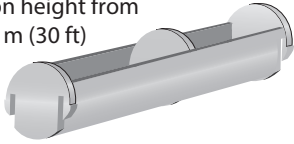

## Acoustic power level

### Specifications:

- 4 diffusers installed in a series of 3 slots each: SAL 35 - 1500 - 3
- Total airflow : 1535 m<sup>3</sup>/h
- Cooling mode: ΔT = - 15 °C
- Heating mode: ΔT = + 15 °C
- Width of space: 4 m
- Length of space: 8 m
- Height of space: 2.74 m
- Head height: 1.8 m

### Required:

1. Air flow by meter of slot
2. Maximum air flow speed in occupied zone V<sub>max</sub>
3. Critical distance in cooling mode X<sub>crit</sub>
4. Loss of pressure ΔP<sub>t</sub>
5. NC value and acoustic power L<sub>WA</sub>

### Solution:

1. For a total air flow of 1535 m<sup>3</sup>/h and 4 SAL 35 diffusers, we find: 1535 x 4 = 384 m<sup>3</sup>/h by diffuser. We divide by the number of slots: 384 m<sup>3</sup>/h ÷ 3 = 128 m<sup>3</sup>/h. Each slot of 1500 mm = 1.5 m in length, we divide by 1.5 to find the air flow per meter of slot: 128 m<sup>3</sup>/h ÷ 1.5 = 85 m<sup>3</sup>/h/m (1)

2. From the sizing diagram, a wall distance x = 2 m (2) and a trajectory after they meet y = 3 m - 1.8 m = 1.2 m, (3) we can find the maximum air speed in the occupied zone of: V<sub>max</sub> = 0.25 m/s (4)

3. For the cooling mode of -15°C, (5) we can determine the critical distance X<sub>crit</sub> = 8.5 m (6)

4. For an airflow by meter of 85 m<sup>3</sup>/h/m slot we read: ΔP<sub>t</sub> = 13 Pa (7)

5. The NC Value and acoustic power for airflow per meter of slot of 85 m<sup>3</sup>/h/m are: L<sub>WA</sub> diagram = 28 dB(A) (8) NC diagram < 15 (9)

From the values shown in the table we calculate: NC diagram = 13 + 7 = 22  
 L<sub>WA</sub> = L<sub>WA</sub> diagram + l = 28 + 4.7 + 7.8 = 40.5 dB(A)  
 40.5 dB(A) - 10 dB(A) = 30.5 dB(A)

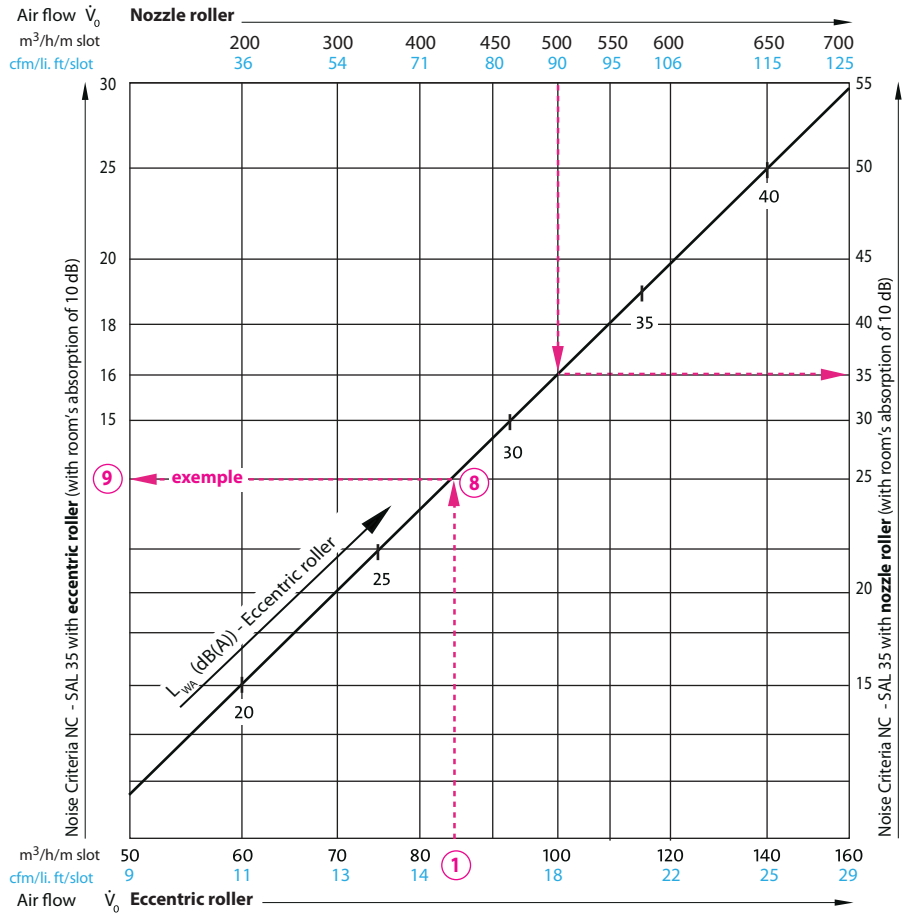

Number of slot	1	2	3	4	5	6	7	8	9	10
k (dB)	0.0	3.0	4.7	6.0	7.0	7.8	8.4	9.0	9.5	10.0
Eccentric rollers NC diagram +	0	3	7	10	13	17	20	24	27	30
Nozzle rollers NC diagram +	0	5	8	11	15	19	24	27	30	34

### How to determine the diffusion length

Diffusers installed in parallel      Diffusers installed in series  
 The length of diffusion: 1.5 m (5 ft)      The length of diffusion: 4.5 m (15 ft)

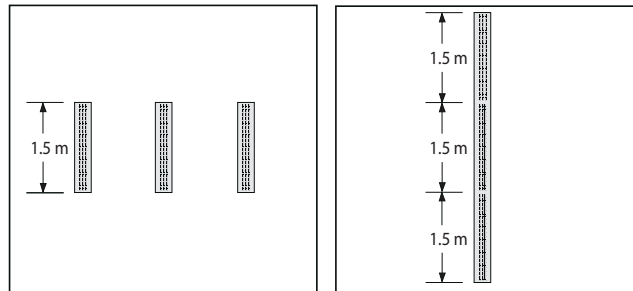

Length of diffusion	dB(A)
1	0.0
2	3.0
3	4.7
4	6.0
5	7.0
6	7.8
7	8.4
8	9.0
9	9.5
10	10.0

### Important :

The absorption of the room is not accounted for. For a comparison with north american values, reduce the acoustic power by 10 dB.





Mississauga University, Mississauga, Canada



# SAL 35

## Dimensions of profile and installation

The SAL 35 is fabricated with wide or narrow diffuser slots made of extruded aluminum surfaces with eccentric rollers.

The diffuser is also available with a custom made steel plate (p.15).

Available dimensions are 300, 400, 500, 600, 700, 800, 900, 1000, 1100, 1200, 1300, 1400, 1500, 1600, 1700, 1800, 1900, 2000 mm. Intermediate dimensions are also available.

A combination of multiple standard lengths allows the creation of a diffuser of the desired length. Two pins ensure an invisible connection between diffusers.

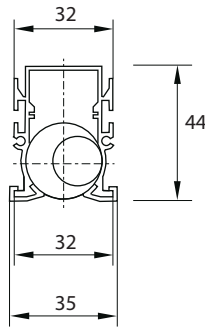

**SAL 35/1**  
One slot SAL 35 profile with narrow profile

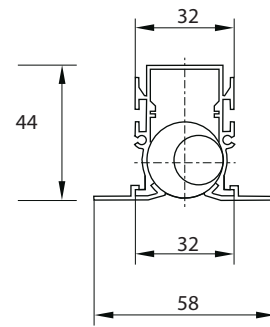

**SAL 35/1**  
One slot SAL 35 profile with wide profile

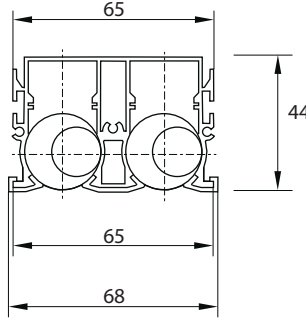

**SAL 35/2**  
Two slots SAL 35 profile with narrow profile

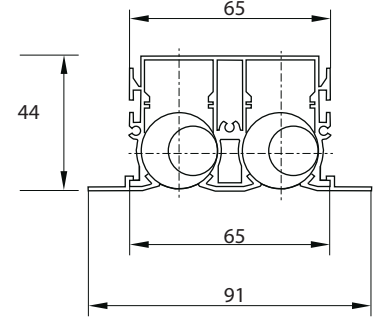

**SAL 35/2**  
Two slots SAL 35 profile with wide profile

### Mounting and suspension for a gypsum ceiling

Attach with the screws provided for this purpose. Suspension of the plenum is achieved with hooks and a threaded rod (not included).

The balancing key (optional) is adjustable per the diffuser.

Position and fix the plenum. Ensure the inlet opening of the diffuser is leveled with the ceiling, simply by pressing on the diffusers inlet.

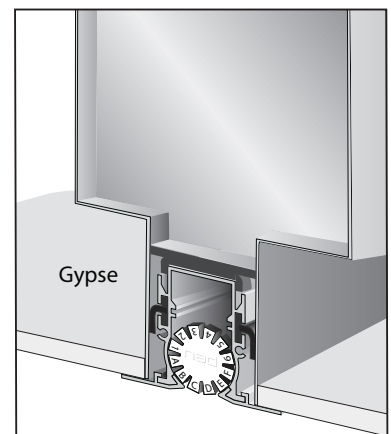
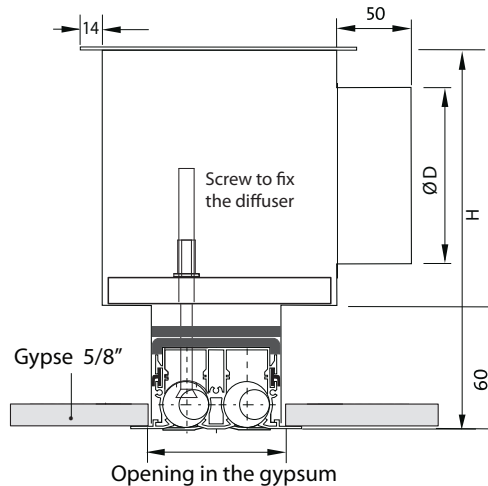
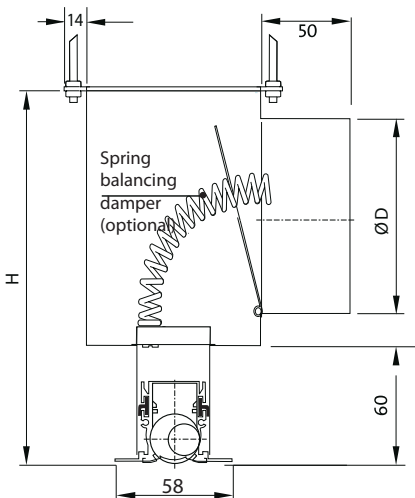
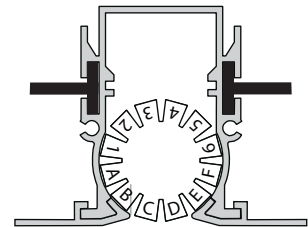



# SAL 35

## Dimensions of diffuser and plenums

### Diffuser and plenum with top inlet

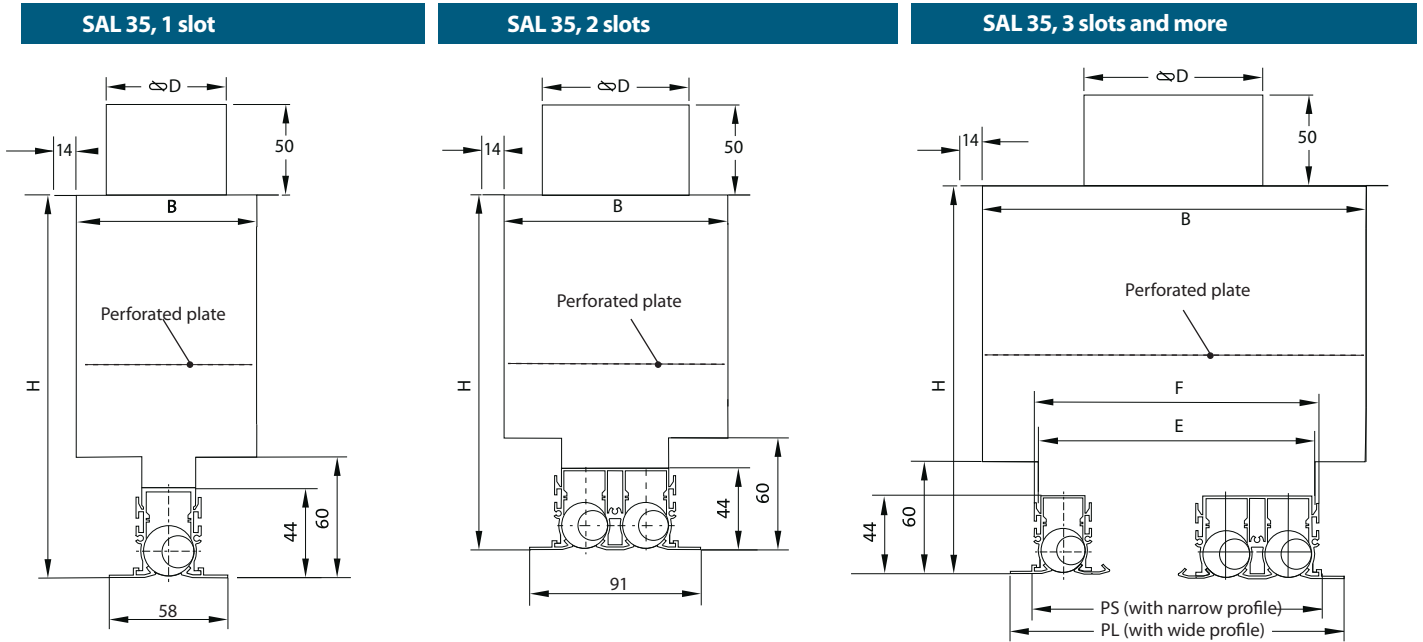

**Note:** The measurements are indicated in the table on pages 12 and 13.

### Diffuser and plenum with side round inlet

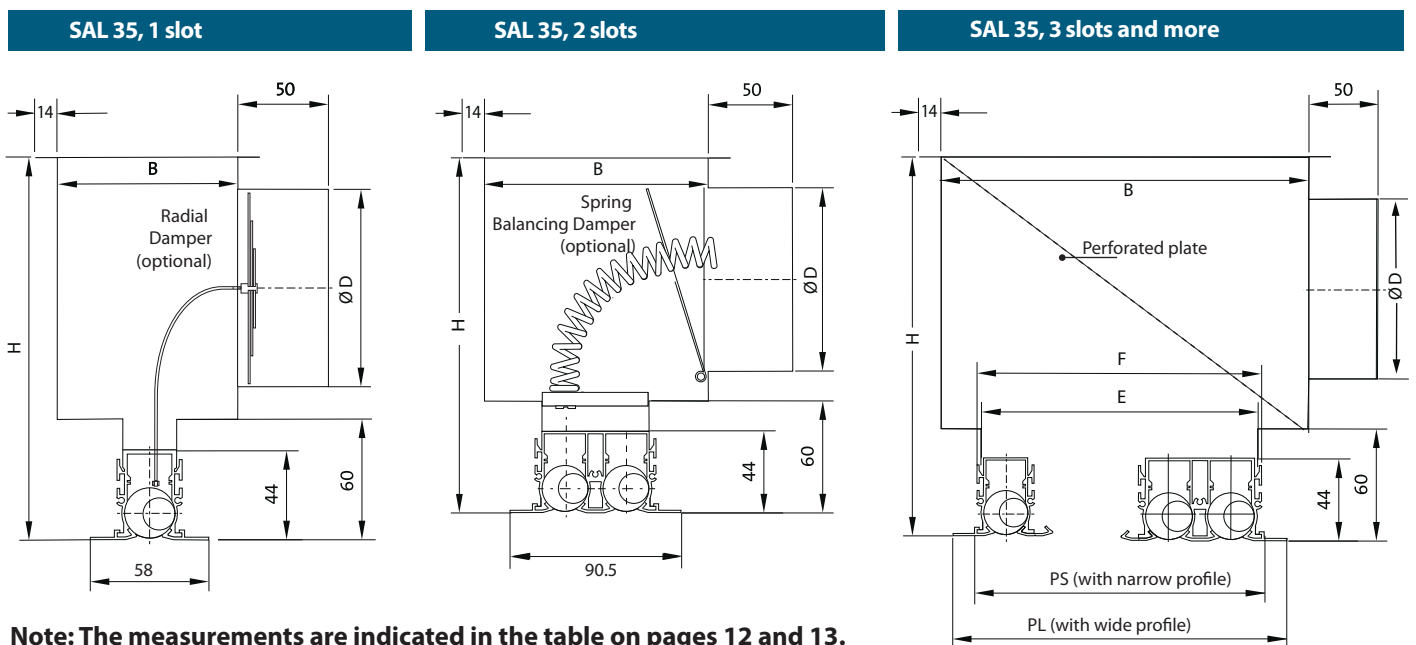

**Note:** The measurements are indicated in the table on pages 12 and 13.

## Dimensions of diffuser and plenum Eccentric rollers

### 1 slot with plenum

Dimensions (mm)	from 300 to 600	from 650 to 900	from 950 to 1500	from 1550 to 2000	
Size B	88	88	88	88	
Size H	286	286	286	286	
Size E	26	26	26	26	
Size F	32	32	32	32	
Size PS	36	36	36	36	
Size PL	58	58	58	58	
Size Ø D	side	125	125	150	2 x 125
	top	125 (oval)	125 (oval)	150 (oval)	2 x 125 (oval)
Air inlet (quantity)	1	1	1	2	

### 2 slots with plenum

Dimensions (mm)	from 300 to 600	from 650 to 900	from 950 to 1500	from 1550 to 2000	
Size B	120	120	120	120	
Size H	342	342	342	342	
Size E	58	58	58	58	
Size F	65	65	65	65	
Size PS	68	68	68	68	
Size PL	91	91	91	91	
Size Ø D	side	150	200	200	2 x 200
	top	150 (oval)	200 (oval)	200 (oval)	2 x 200 (oval)
Air inlet (quantity)	1	1	1	2	

### 3 slots with plenum

Dimensions (mm)	from 300 to 600	from 650 to 900	from 950 to 1500	from 1550 to 2000	
Size B	152	152	152	152	
Size H	342	342	342	342	
Size E	90	90	90	90	
Size F	97	97	97	97	
Size PS	98	98	98	98	
Size PL	123	123	123	123	
Size Ø D	side	150	200	250	2 x 200
	top	150 (oval)	200 (oval)	250 (oval)	2 x 200 (oval)
Air inlet (quantity)	1	1	1	2	

### 4 slots with plenum

Dimensions (mm)	from 300 to 600	from 650 to 900	from 950 to 1500	from 1550 to 2000	
Size B	184	184	184	184	
Size H	392	392	392	392	
Size E	122	122	122	122	
Size F	130	130	130	130	
Size PS	134	134	134	134	
Size PL	156	156	156	156	
Size Ø D	side	200	200	250	2 x 250
	top	200 (oval)	200 (oval)	250 (oval)	2 x 250 (oval)
Air inlet (quantity)	1	1	1	2	

### 5 slots with plenum

Dimensions (mm)	from 300 to 600	from 650 to 900	from 950 to 1500	from 1550 to 2000	
Size B	216	216	216	216	
Size H	392	392	392	392	
Size E	154	154	154	154	
Size F	162	162	162	162	
Size PS	166	166	166	166	
Size PL	188	188	188	188	
Size Ø D	side	200	250	302	2 x 250
	top	200 (oval)	250 (oval)	302 (oval)	2 x 250 (oval)
Air inlet (quantity)	1	1	1	2	

### 6 slots with plenum

Dimensions (mm)	from 300 to 600	from 650 to 900	from 950 to 1500	from 1550 to 2000	
Size B	248	248	248	248	
Size H	392	392	392	392	
Size E	187	187	187	187	
Size F	195	195	195	195	
Size PS	199	199	199	199	
Size PL	221	221	221	221	
Size Ø D	side	200	250	302	2 x 250
	top	200	250 (oval)	302 (oval)	2 x 250 (oval)
Air inlet (quantity)	1	1	1	2	

## Dimensions of diffuser and plenum Eccentric rollers

### 7 slots with plenum

Dimensions (mm)	from 300 to 600	from 650 to 900	from 950 to 1500	from 1550 to 2000	
Size B	280	280	280	280	
Size H	392	392	457	392	
Size E	219	219	219	219	
Size F	227	227	227	227	
Size PS	231	231	231	231	
Size PL	253	253	253	253	
Size $\varnothing$ D	side	200	250	353	2 x 250
	top	200	250	353 (oval)	2 x 250
Air inlet (quantity)	1	1	1	2	

### 8 slots with plenum

Dimensions (mm)	from 300 to 600	from 650 to 900	from 950 to 1500	from 1550 to 2000	
Size B	312	312	312	312	
Size H	392	392	457	392	
Size E	251	251	251	251	
Size F	260	260	260	260	
Size PS	264	264	264	264	
Size PL	286	286	286	286	
Size $\varnothing$ D	side	250	302	353	2 x 302
	top	250	302 (oval)	353 (oval)	2 X 302 (oval)
Air inlet (quantity)	1	1	1	2	

### 9 slots with plenum

Dimensions (mm)	from 300 to 600	from 650 to 900	from 950 to 1500	from 1550 to 2000	
Size B	344	344	344	344	
Size H	392	392	457	392	
Size E	283	283	283	283	
Size F	292	292	292	292	
Size PS	296	296	296	296	
Size PL	318	318	318	318	
Size $\varnothing$ D	side	250	302	353	2 x 302
	top	250	302	353 (oval)	2 x 302
Air inlet (quantity)	1	1	1	2	

### 10 slots with plenum

Dimensions (mm)	from 300 to 600	from 650 to 900	from 950 to 1500	from 1550 to 2000	
Size B	376	376	376	376	
Size H	392	392	457	392	
Size E	315	315	315	315	
Size F	325	325	325	325	
Size PS	329	329	329	329	
Size PL	351	351	351	351	
Size $\varnothing$ D	side	250	302	353	2 x 302
	top	250	302	353 (oval)	2 x 302
Air inlet (quantity)	1	1	1	2	

### Total length with end cap

PL2, PLR, PLL

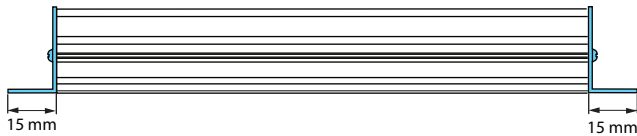

PS2, PSR, PSL

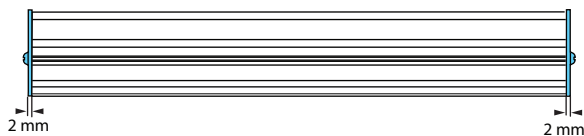

PLP, PSP

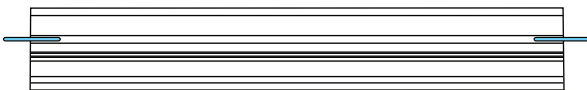

Nominal Size	PLP/PSP mm	PLL/PLR mm	PL2 mm	PSR/PSL mm	PS2 mm
300	298	313	328	300	302
400	398	413	428	400	402
500	497	512	527	499	501
<b>600</b>	<b>573</b>	<b>588</b>	<b>603*</b>	<b>575</b>	<b>577</b>
700	696	711	726	698	700
800	795	810	825	797	799
900	895	910	925	897	899
1000	994	1009	1024	996	998
1100	1093	1108	1123	1095	1097
<b>1200</b>	<b>1183</b>	<b>1198</b>	<b>1213*</b>	<b>1185</b>	<b>1187</b>
1300	1292	1307	1322	1294	1296
1400	1392	1407	1422	1394	1396
1500	1491	1506	1521	1493	1495
1600	1590	1605	1620	1592	1594
1700	1690	1705	1720	1692	1694
1800	1789	1804	1819	1791	1793
1900	1889	1904	1919	1891	1893
2000	1988	2003	2018	1990	1992

\* Dimensions modified for insertion into a suspended ceiling



## Dimensions of diffuser and plenum Rollers nozzle

### 1 slot with plenum

Dimensions (mm)	from 300 to 600	from 650 to 900	from 950 to 1500	from 1550 to 2000	
Size B	120	120	120	120	
Size H	342	342	342	342	
Size E	26	26	26	26	
Size F	32	32	32	32	
Size PS	35	35	35	35	
Size PL	58	58	58	58	
Size Ø D	side	150	200	250	2 x 200
	top	150 (oval)	200 (oval)	250 (oval)	2 x 200 (oval)
Air inlet (quantity)	1	1	1	2	

### 2 slots with plenum

Dimensions (mm)	from 300 to 600	from 650 to 900	from 950 to 1500	from 1550 to 2000	
Size B	184	184	184	184	
Size H	392	392	392	392	
Size E	58	58	58	58	
Size F	65	65	65	65	
Size PS	68	68	68	68	
Size PL	91	91	91	91	
Size Ø D	side	200	250	302	2 x 250
	top	200 (oval)	250 (oval)	302 (oval)	2 x 250 (oval)
Air inlet (quantity)	1	1	1	2	

### 3 slots with plenum

Dimensions (mm)	de 300 to 600	de 650 to 900	de 950 to 1500	de 1550 to 2000	
Size B	248	248	248	248	
Size H	392	392	392	392	
Size E	90	90	90	90	
Size F	96.5	96.5	96.5	96.5	
Size PS	98	98	98	98	
Size PL	122.5	122.5	122.5	122.5	
Size Ø D	side	250	302	353 (oval)	2 x 302
	top	250 (oval)	302 (oval)	353 (oval)	2 x 302 (oval)
Air inlet (quantity)	1	1	1	2	

### 4 slots with plenum

Dimensions (mm)	from 300 to 600	from 650 to 900	from 950 to 1500	from 1550 to 2000	
Size B	248	248	248	248	
Size H	392	392	392	392	
Size E	122	122	122	122	
Size F	130	130	130	130	
Size PS	133	133	133	133	
Size PL	155	155	155	155	
Size Ø D	side	250	302 (oval)	2 x 302	2 x 353 (oval)
	top	250 (oval)	302 (oval)	2 x 302 (oval)	2 x 353 (oval)
Air inlet (quantity)	1	1	2	2	

### 5 slots with plenum

Dimensions (mm)	from 400 to 600	from 650 to 900	from 950 to 1500	from 1550 to 2000	
Size B	344	344	344	344	
Size H	457	457	457	457	
Size E	154	154	154	154	
Size F	162	162	162	162	
Size PS	165	165	165	165	
Size PL	188	188	188	188	
Size Ø D	side	302	353	2 x 302	2 x 353 (oval)
	top	302	353 (oval)	2 x 302 (oval)	2 x 353 (oval)
Air inlet (quantity)	1	1	2	2	

### 6 slots with plenum

Dimensions (mm)	from 400 to 600	from 650 to 900	from 950 to 1500	from 1550 to 2000	
Size B	344	344	344	344	
Size H	457	457	457	457	
Size E	187	187	187	187	
Size F	195	195	195	195	
Size PS	198	198	198	198	
Size PL	221	221	221	221	
Size Ø D	side	302	353	2 x 353	2 x 403 (oval)
	top	302 (oval)	353 (oval)	2 x 353 (oval)	2 x 403 (oval)
Air inlet (quantity)	1	1	2	2	

For higher air volume, diffusers will be custom made.  
The dimensions and prices will be available upon request.

## End caps and connectors

### PS with narrow profile

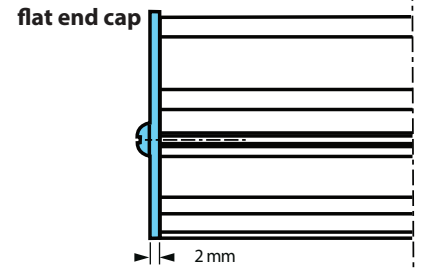
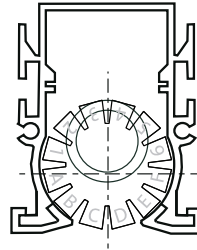
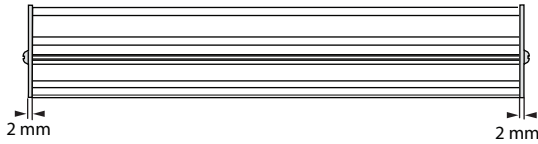

PS2 : with flat end cap on both sides  
 PSR : with flat end cap on right side  
 PSL : with flat end cap on left side

### PL with wide profile ("L")

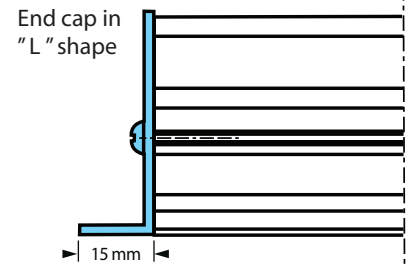
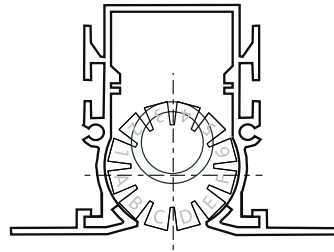
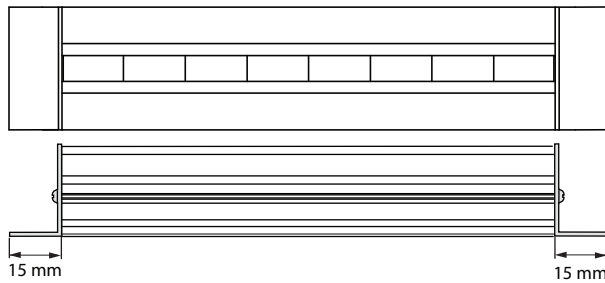

PL2: with wide end on both sides  
 PLR: with wide end on right side  
 PLL: with wide end on left side

### APA for the steel plate (custom made)

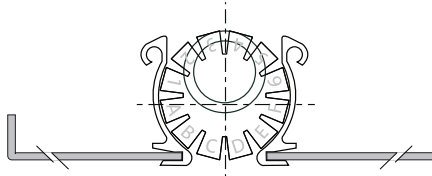
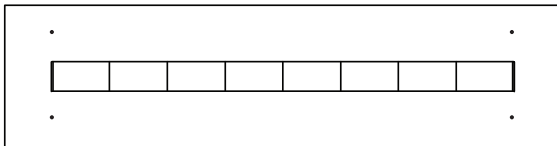

**Note:** it is essential to write in annotation the overall dimensions of the steel plate you need (in mm).

### Connectors (pins)

The connection between diffusers is made with pins (included) when diffusers are installed in series.

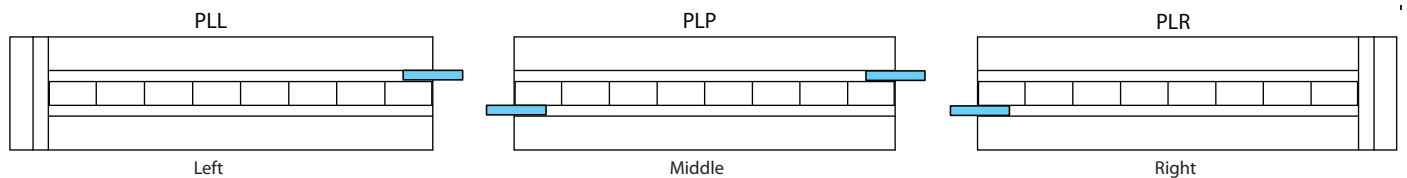
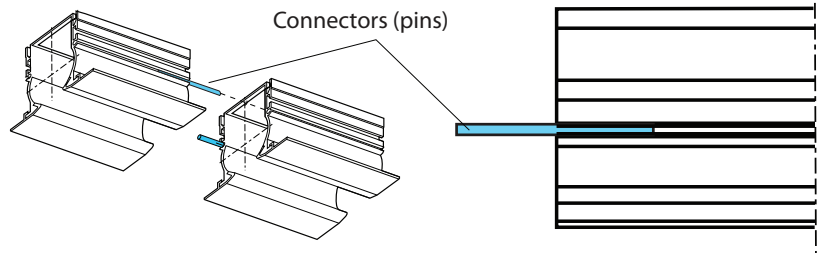



## Specifications

### 1. Description and physical characteristics

- 1.1 The high induction linear diffuser shall be made of extruded aluminum profiles.
- 1.2 The 100 mm long eccentric rollers shall have an alphanumeric identification, which will allow an adjustment of the air flow pattern over 180 degrees.
- 1.3 The diffuser shall be adjustable to fit regular North American suspended ceilings, classic gypsum ceilings or wall installations.
- 1.4 The diffuser shall be supplied with a wide or narrow profile.
- 1.5 The diffuser shall be powder coated with a polyester TGIC-free paint, providing a smooth, easy-to-clean, chip and fade resistant finish. The architect or client shall choose a standard colour from the RAL colour chart.

### 2. Performance

- 2.1 The performance shall be guaranteed by using performance curves or simulation software for critical areas. These curves shall indicate the pressure drop, acoustic power generated as well as showing a cross-sectional view, illustrating the critical airflow path in cooling, isothermal and heating modes.
- 2.2. **Parameters of guaranteed comfort**
- 2.2.1 The performance statistics of the diffuser shall reflect a maximum air speed of 0.15 m/s (30 ft/m), in occupied zone at 1.3 m (4 ft) from the floor. The performance guarantee shall be demonstrated with performance curves showing the path of the air stream.
- 2.2.2 The diffuser shall ensure a maximum temperature difference of -1°C between the air jet and the occupied area 4 ft (1.3 m) above the floor. To achieve this, the ratio of temperature differential shall perform at a minimum of  $\Delta T_{xy} / \Delta T_0 \leq 0.1$  (for an initial differential of  $\Delta T_0 = -10^\circ\text{C}$ ).

2.2.3. In cooling mode, the diffuser shall guarantee, in variable volume (VAV), a critical distance ( $X_{crit}$ ) of at least the value is indicated in the following table:

Diffuser inlet (in)	6	8	10	12
Air flow max. (pcm)	80-150	151-280	281-400	401-600
min. (pcm)	20-40	41-90	91-140	141-200
X critical - ft	1'- 7"	1'- 11"	2'- 3"	2'- 7"
(m)	0.5	0.6	0.7	0.8

### 3. Plenum

- 3.1 The diffuser shall include a plenum provided by the manufacturer. The plenum shall be made from 24 gauge galvanised steel and comprise suspension points at the four corners. The inlet collar shall be centered on the side and adapted to the air flow. The interior joints of the plenum shall be assembled by clinching and sealed with silicon.
- 3.2 When required, the plenum shall be supplied with a damper adjustable through the finished side of the front plate, in order to adjust the air volume. This damper shall be available in two options:
- 3.2.1 **Radial damper:** Key with circular pivoting blades on a flexible metallic cable, which is adjustable through the front plate of the diffuser, allowing for air flow adjustment from 0% to 100%.
- 3.2.2 **Spring key:** Pivotaly perforated plate at the inlet, adjustable with a spring mechanism through the front of the diffuser.

### 4 - Balancing

- 4.1 The balancing shall be executed by a ventilation balancing technician with a recognised professional certification.
- 4.2 The technician shall take into account the volume correction factor using a balometer (FCB factor).

### 5 - Required quality: NAD Klima, SAL 35 model.

# SAL 35

## Codification

<b>SAL 35</b>	<b>Product</b>
0300, 0400, 0500, 0600, 0700, 0800, 0900, 1000, 1100, 1200, 1300, 1400, 1500, 1600, 1700, 1800, 1900, 2000	<b>Length of diffuser</b>
1, 2, 3, 4, 5, 6, 7, 8, 9, 10	<b>Number of slots</b>
DFS = Standard diffuse 21 / 65 DFL = Window diffuse BC / 65 DFR = Window diffuse DE / 21 DFH = Diffuse height BC / DE DFE = Diffuse window (max. 4 m) BC / EF DFF = Diffuse AB / EF DFN = Diffuse CD / AB DFT = Diffuse CD / EF DVB = Divergent 21 DVD = Divergent 65 DVM = Wall divergent DE (jet towards the ceiling) DVV = Vertical divergent CD DRB = Divergent with roller nozzles	<b>Airflow</b>
PL2 = Wide profile with end cap in "L" shape on both sides PLL = Wide profile with end cap in "L" shape on left side PLR = Wide profile with end cap in "L" shape on right side PLP = Wide profile without an end cap (with pins) PS2 = Narrow profile with flat end cap on two sides PSL = Narrow profile with flat end cap on left side PSR = Narrow profile with flat end cap on right side PSP = Narrow profile without end cap (with pull pins) APA = With a steel frontal plate * (Write the dimensions you need (in mm) in annotation)	<b>Profile and end cap</b>
W = White eccentric rollers or roller nozzles - (RAL 9003) C = Cream eccentric rollers or roller nozzles - (RAL 9010) B = Black eccentric rollers or roller nozzles	<b>Colour of eccentric rollers or roller nozzles</b>
9003 = White 9010 = Cream 00SB = Solar black (Standard matte black) 00SM = Matte silver (Standard metallic gray) _____ = RAL colour (indicate the number of the colour)	<b>Diffuser colour</b>
S = Plenum with inlet on the side T = Plenum with inlet on the top X = Without plenum	<b>Plenum</b>
I = With acoustic insulation A = With closed cell acoustic insulation X = Without insulation	<b>Acoustic insulation</b>
F = With fireproof insulation and fireproof dampers (balancing damper not available) X = Without fireproof insulation and fireproof dampers	<b>Fireproof insulation</b>
D = With spring damper R = With radial damper ** X = Without damper	<b>Balancing damper</b>
G = Gypsum ceiling W = Wall X = Suspended ceiling R = Return Grille (SAL 35 without connection plenum)	<b>Type of installation</b>
<b>SAL 35 - 0300 - 1 - DFS - PL2 - B - 9003 - S - X - X - X - X</b>	<b>Example</b>

Notes:

\* For the APA model, it is essential to indicate the overall dimensions of the steel plate you need (in mm), in annotation.

\*\* Not available on oval collar



Sherweb, Sherbrooke, Canada



Audi automobiles, Laval, Canada





Private residence, Sherbrooke, Canada

nad  
K L I M A

[www.nadklima.com](http://www.nadklima.com)

**NAD Klima**

144, rue Léger,  
Sherbrooke, QC, J1L 1L9 Canada  
T: 819 780-0111 • 1 866 531-1739

[info@nadklima.com](mailto:info@nadklima.com)

---

MADE IN  
  
CANADA